

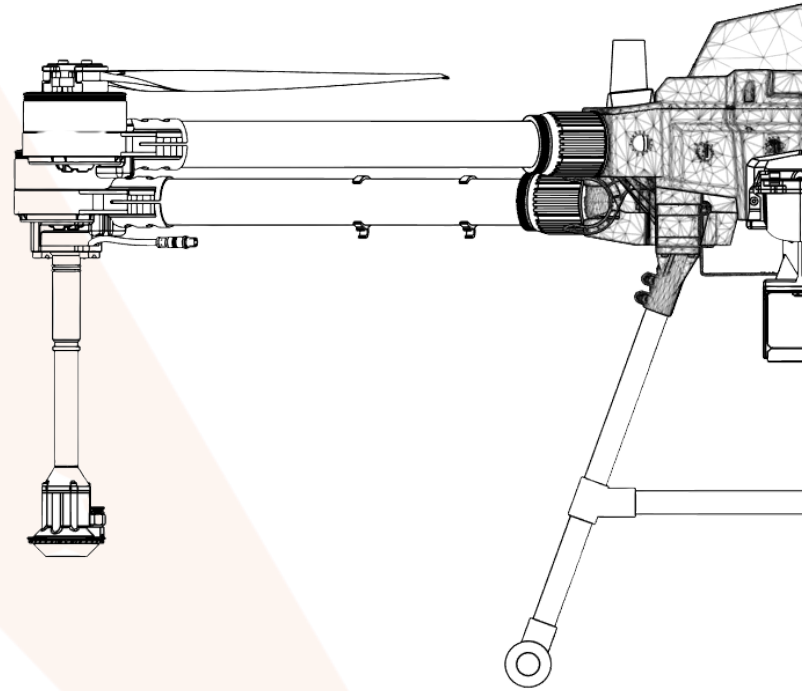

ABZ
INNOVATION
WE BUILD DRONES.



L10 M12

OPERATOR MANUAL

Version 2.4

General Information Overview

This manual is for the ABZ Innovation M12 industrial, multi-payload drone, which can be upgraded with a wide range of payloads, thanks to its universal design.

The drone and its accessories may only be operated in accordance with the instructions in this manual.

Please read this notice and the manual provided for your ABZ Innovation M12 drone before use.

If you have any questions, please contact ABZ Innovation customer service before use.

The contact details can be found at the end of this document. By using the drone, you declare that you have read this manual, that you understand and acknowledge the information contained herein, and that you consent to use the drone only under proper conditions, in full compliance with applicable laws and the instructions in this manual. Furthermore, you agree that you are now exclusively responsible for the drone and its operation, and for any direct or indirect legal consequences arising from its operation.

The ABZ Innovation M12 drone is NOT a toy and is to be used only with care. Improper use of the drone poses a serious risk and can cause damage to the drone and its surroundings, severe personal injury or death. The drone may only be used by qualified pilots. The ABZ Innovation M12 is a technical, industrial device.

Any modification to the drone, its components or software will immediately void the warranty.

The M12 drone is a single-variant-only model of ABZ Innovation, no other model combinations are available, no configuration changes are applicable to this drone model.

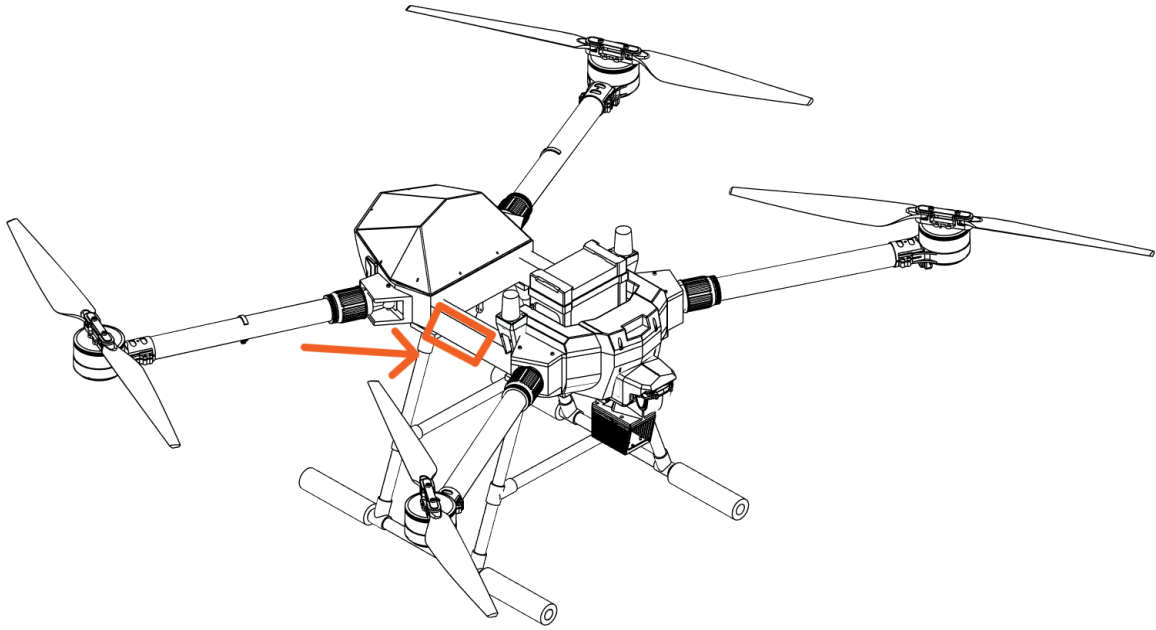

To identify an M12, locate the serial number label on the right side of the drone frame.

	RID/SN: 1759FABZL10M12	
	Date of manufacture: 2025.09.21.	
	Input: Battery - 44.4V 55A	
	This device complies with:	
	ASTM F3411-22a-RID-B and and 14 CFR Part 89	
	This device complies with part 15 of the FCC Rules. Operation is subject to the following two conditions: (1) This device may not cause harmful interference, and (2) this device must accept any interference received, including interference that may cause undesired operation.	
	Safety warning: Hazardous moving parts, keep clear!	
	Make - model - series: ABZ Innovation - L10 - M12	
	Manufacturer: ABZ Innovation Kft.	
Made in Hungary (EU)		
Address: Kalászi út 3, Szentendre, 2000, Hungary		
This device contains FCC IDs:		
FCC ID: XPYANNAB4	FCC ID: 2ABCB-RPI5	
FCC ID: 2AZBB-MK15RX	FCC ID: RID-LR101H	

This device complies with Part 15 of the FCC Rules. Operation is subject to the following two conditions: (1) This device may not cause harmful interference, and (2) this device must accept any interference received, including interference that may cause undesired operation.

This device contains the following FCC-certified modules: FCC ID: XPYANNAB4, FCC ID: 2AZBB-MK15RX, FCC ID: RID-LR101H, FCC ID: 2ABCB-RPI5

This device complies with Part 15 of the FCC Rules for Class A digital devices. NOTE: This equipment has been tested and found to comply with the limits for a Class A digital device, pursuant to part 15 of the FCC Rules. These limits are designed to provide reasonable protection against harmful interference when the equipment is operated in a commercial environment. This equipment generates, uses, and can radiate radio frequency energy and, if not installed and used in accordance with the instruction manual, may cause harmful interference to radio communications. Operation of this equipment in a residential area is likely to cause harmful interference in which case the user will be required to correct the interference at his own expense.

Responsible Party:

Drone Nerds 5553 Anglers Ave, Suite #109, Ft. Lauderdale, FL 33312 Phone:(786) 708-7807, Email: sales@dronenerds.com

ABZ Innovation M12 drone

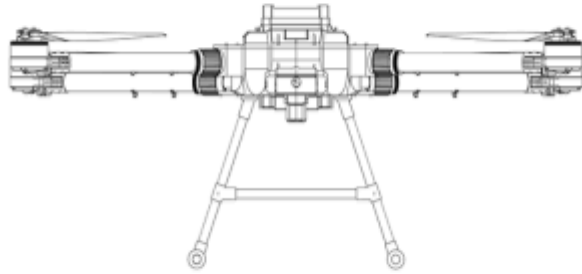

Front

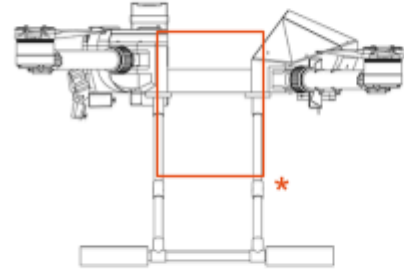

Side

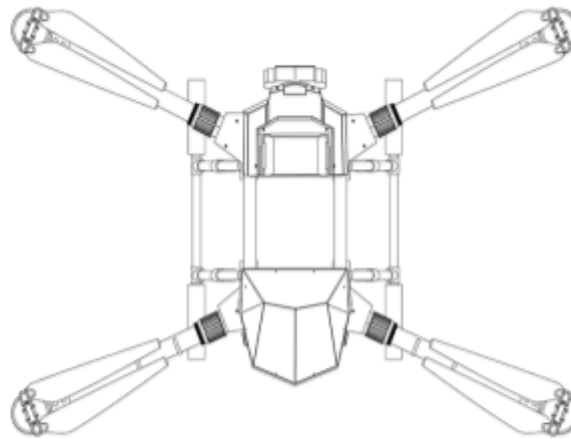

Top

* Optimal payload area

Drone main parts

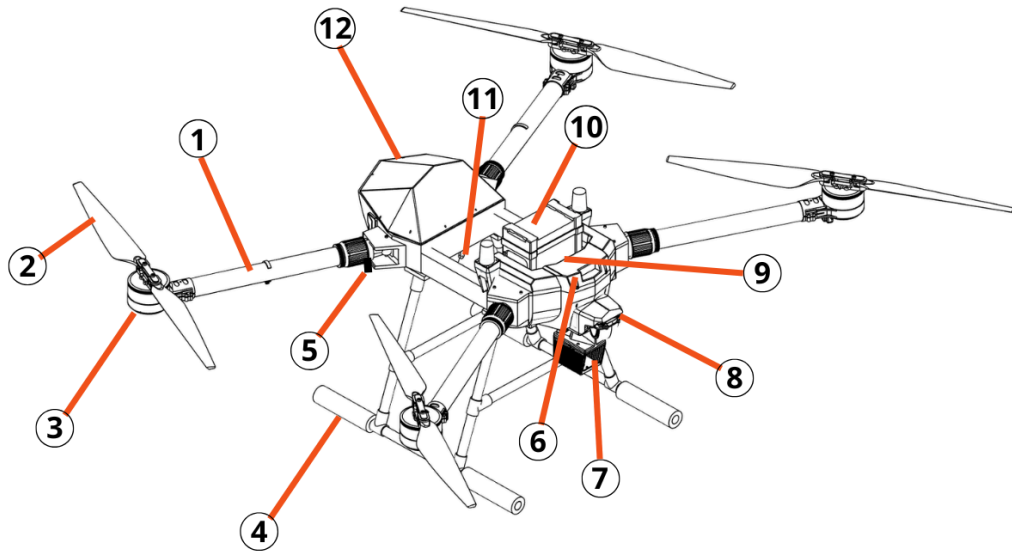

- | | |
|-----------------|--------------------------|
| 1: Arms | 7: LiDAR (Optional) |
| 2: Propellers | 8: Camera |
| 3: Motors | 9: Battery connector |
| 4: Landing gear | 10: Battery |
| 5: RC antennas | 11: Optimal payload area |
| 6: Front cover | 12: Rear cover |

The drone is available from the manufacturer only in one hardware and software configuration, without any additional payload.

Specifications

General specifications		
	EU	US
Payload	9.1 kg	20 lbs
Max. take-off weight	24.9 kg	54.9 lbs
Total weight (with battery) *	15.8 kg	34.8 lbs
Total weight (without battery) *	11.6 kg	25.6 lbs
Maximum characteristic dimension **	2300 mm	90.5 in
Dimensions (arms & propellers unfolded) (L x W x H)	2060 x 1600 x 600 mm	81.1 x 63 x 23.6 in
Dimensions (arms and propellers folded) (L x W x H)	770 x 540 x 600 mm	30.3 x 21.3 x 23.6 in
Effective signal range of RC	~3.5 km	~2.17 mi
Payload connections		
Power source	5V, 12V, Battery voltage	5V, 12V, Battery voltage
Communication ports	I2C, UART, CAN, USB	I2C, UART, CAN, USB
Signal inputs/outputs	PWM, GPIO	PWM, GPIO
Frequency bands		
Radio Control and Telemetry	2.4GHz	2.4GHz
WLAN	2.4GHz	2.4GHz
Flight		
Max. operating flight speed	8 m/s	17.9 mi/h
Max. level speed	15 m/s	33.5 mi/h
Max. tolerable wind speed	10 m/s	22.4 mi/h

Packing list

The M12 drone standard package contains:

- M12 drone
- ABZ Innovation MK15 remote controller with sticks and antennas
- Charger cable for remote controller
- 20 W fast charger and cable for remote controller
- US/EU plug converter for the fast charger
- Carrying case for the remote controller

Safety requirements

Child protection provisions

- This equipment is not suitable for use in places where children are likely to be present.
- The equipment must be kept out of the reach of children.
- The equipment operates rotating parts that are dangerous for children and must be kept out of the reach of children!

Operating conditions

- It is forbidden to operate the drone or any of its components in an enclosed space.
- Fly only in places where there are no buildings or other obstacles.
- Do not fly over or near people.
- Do not fly above 4.5 km (14 763 feet) above sea level.
- Fly only in moderate weather conditions, between temperatures of 5°C and 45°C (41°F and 113°F).
- Rain and foggy weather might affect the performance of the LiDAR, and consequently, the performance of altitude hold and obstacle sensing.
- Do not fly in rain, hail, or in higher relative humidity than 80%.
- During lightning, flight is prohibited.
- During adverse weather conditions, such as heavy rain, snow, and icing, flight is prohibited.
- Your flying activities must not violate any applicable laws or regulations. You must have all necessary permits. Contact the appropriate government agency or authority before flying to ensure that you are operating your drone in compliance with laws and regulations.
- Avoid contact with any solid objects or animals during flight, even smaller particles (excessive sand, dust, or swarm of insects) can cause damage to the propellers, when contacting at high (rotational) speed.
- The pilot must ensure that during the entire flight, VLOS conditions are assured. Flight in excessive fog, dust, etc. is prohibited.
- In dark lighting conditions the pilot must reduce the maximum flight distance to a limit, where the drone and its orientation is safely determined based on the light of the LEDs.
- In all flight modes including take-off and landing, the pilot must comply with all safety requirements and the technical conditions must be met.
- When recording a video or picture, the privacy and property rights must be met. Recordings are only allowed with authorization of every involved person, including private property.

- In case of using sensors capable of personal data detection, the UAS operator needs to be registered to meet the legal requirements. Especially in these cases, calculate the permitted distance using Detection-Recognition-Identification metrics and fly only where recordings are only in Detection and/or Recognition range and not in the Identification range.

Operation

- The drone may only be switched on and operated in accordance with the "[Flight Protocol](#)" chapter starting on page 101.
- Only use the drone in full compliance with the [Checklists](#).
- Stay away from rotating propellers and motors.
- Do not exceed the maximum combined accessories and batteries, and payload weight in any case. Otherwise, the drone may be damaged and the flight might pose danger.
- Always keep track of the drone's flight, be ready for manual control. Manually avoid obstacles at a safe distance. Never rely exclusively on the ABZ Control app. It is important to check or set the correct Failsafe and RTL altitude before each flight.
- Always keep the drone within visual line of sight (VLOS) and keep an eye on it.
- Don't get distracted by using your mobile phone or any other activities.
- Don't fly under the influence of alcohol, drugs, or medicines. Fly only when you are mentally and physically capable of safely controlling the drone, including paying attention to its surroundings.
- If the drone or remote controller battery is low, land the drone in a safe place. The state of the drone battery should be monitored before the flight using the charging indicator LEDs on the battery. We recommend starting the flight with a minimum of 80% battery charge.
- During the flight, the pilot must monitor the battery voltage, which should always be above 43.5V, even when flying with the Maximum Take-off Mass (MTOM). The ABZ Control battery indicator icon serves only as an indicator and shows an approximate value.
- Never fly closer than 100 m (328 ft) to a high-voltage power line or high-power radio emitters (e.g. Radar, TV/Radio station).
- Never fly closer than 30 m (100 feet) horizontal distance to buildings.
- After landing, switch off the motors, switch off the drone by disconnecting the battery, and then switch off the remote controller.
- In case of loss of remote controller signal, the drone can automatically switch to Failsafe RTL mode.

Maintenance and storage

- Do not use damaged, broken, or aged propellers.
- Regularly check the condition of the drone and make a flight log.
- To avoid damage to the drone's landing gear, remove payloads, accessories and the battery before transportation.
- Significant dust and stains on the optical window will affect the performance of the LiDAR sensor.
 - If it is necessary to clean the sensor, first use compressed or canned air. DO NOT wipe a dusty optical window, as it will only cause more damage.
 - If the optical window has visible stains after dusting, it is necessary to wipe it as well.
 - DO NOT wipe using a dry lens tissue, as it will scratch the surface of the optical window. Use a lens tissue with isopropyl alcohol. Wipe slowly to remove the dirt instead of redistributing it on the surface of the optical window.
 - If the optical window is still dirty, a mild soap solution can be used to gently wash the window. Repeat Step 2 to remove any remaining soap residue.
- Never take pictures of the LiDAR while it is operating. The laser pulses emitted by the LiDAR may damage the mobile phone's camera sensor.
- Clean the drone, especially the propellers, after use.
- Recommended storage temperature: between 5°C and 40°C (41°F and 104°F) applicable for the drone, as well as the remote controller and the batteries.
- Never store the remote controller or the drone's batteries below 0°C (32°F), as it will cause excessive degradation to the battery cells.
- Store the drone, remote controller, and batteries below 60% relative humidity.
- The remote controller and the drone's batteries must be stored at about 60% charge.
- Batteries deplete after extended storage. The remote controller and the drone's batteries must be inspected monthly and discharged and recharged every three months during storage.
- After long-term storage:
 - Every battery must be inspected and fully charged before use.
 - The drone's motors must be inspected for free rotation.

Drone handling and use precautions

- Before commencing each flight, pay attention to the following:
 - working at a suitable time of day,
 - weather conditions,
 - environmental influences (such as sunlight),
 - drifting of the drone in case of wind,
 - when planning, the correct cornerpoint/route spacing,
 - wind speed,
 - flight altitude,
 - obstacles in the work area.
- The equipment is powered by a replaceable battery. Make sure the batteries are in good condition and fully charged. Do not use faulty or damaged batteries. To learn about proper use and storage, please read the battery's instruction manual.
- The batteries can be charged using an external battery charger. To use this, please refer to the battery charger's instructions for use.
- The battery performance varies by temperature, so always pay attention to this phenomenon and follow the battery's instruction manual. Operate or charge the batteries only between 5°C and 45°C (41°F and 113°F) ambient temperatures, while the battery's temperature remains between 10°C and 60°C (50°F and 140°F).
- Battery discharge is not linear, depending on load, temperature, internal resistance, and condition of cells. This figure shows the typical discharge curve for a drone battery in 90% state of health, at 40°C at 7,5C load:

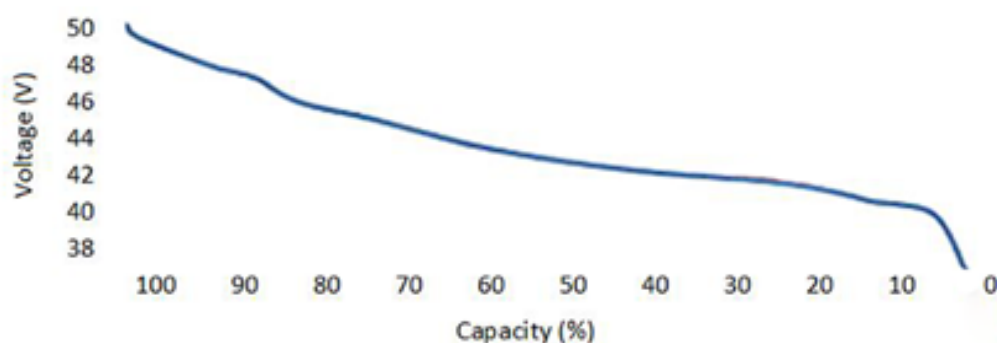

- The maximum masses of accessories/batteries/payloads combined, fitted to the drone must not exceed (29.1 lbs / 13.2 kg), thereby the drone's overall mass must not exceed the Maximum Take-off Mass (MTOM) 54.9 lbs / 24.9 kg.
- Maximum flight time with one battery is mostly dependent on the Take-off Mass, which is highly related to installed accessories and payloads. The difference in safe maximum flight time between an unequipped M12 and a fully loaded M12 at MTOM can be as high as 10 minutes.
- The drone's agility and balance are highly influenced by the payloads or accessories, especially if those are installed further away from the Optimal payload area (shown on page 3). If a heavier device is installed offset from the drone's center of gravity, the pilot must fly with extreme caution to the altered controllability and potential of slower deceleration, acceleration, turning, elevation, and descent speeds.

Information about transport

The drone is designed for outdoor work. The drone can be delivered to the site in the trunk of a vehicle, in the loading area of a truck, or in a trailer. Always apply the protective foam fixations to the propellers before moving the drone with folded arms. Proper anchorage is an important prerequisite for the safe transport of the drone, as it is done on uneven road surfaces and on various terrain. Securing the drone improperly can cause damage such as deformation and ultimately breakage of the propellers, damage, punctures, damage to the fastenings, payloads, etc...

Transporting the equipment requires extra care and attention. Improperly secured equipment and accessories necessary for its operation (drone, drone batteries, battery charger, generator, etc...) can lead to damage, which may ultimately lead to total equipment failure. Therefore, please carefully secure the drone during transport and store its accessories in a suitable place.

In case of loss of signal and communication

General Failsafe

The ABZ Innovation L10 V2 drone's software is equipped with safety features that ensure safe operation at all times. These include possible loss of signal and communication. This can occur when the drone signal is out of range, obstructed by a hill or building, or affected by interference from nearby equipment, electronic devices, or magnetic sources. In these cases, the drone will communicate clear instructions to the operator while the software initiates safety functions. The safety features [can be set before take-off](#), telling the drone what to do if the drone loses signal.

These options can also be set with the following:

- Returning to the starting point (Return to Launch – RTL)
- Landing
- continuing Auto mission

If the drone loses signal from the remote controller, or the communication between these are interrupted, on the remote controller's screen the following message will appear: „COMMUNICATION LOST” and it will read it out loud (if the volume is not muted).

The drone and the remote controller will try to recover the connection automatically. However, if possible, it is highly recommended for the pilot to move the remote controller closer to the drone, especially if any obstacles (e.g. building, tree, or a hill) are in between, and also if the communication between the remote controller and the drone is recovered, take back manual control of the drone (e.g. switching to Manual (Loiter) mode).

Low Power Condition

Battery Failsafe

The L10 V2 drone is equipped with safety procedures to ensure that it operates only with safe battery levels. If the battery voltage reaches the low threshold (42.5 V), the drone will automatically initiate Return-to-Launch (RTL) mode. If, during RTL, the battery reaches the critical threshold (42 V), the drone will land immediately.

Regardless of the battery failsafe system in place, the pilot must continuously monitor the battery voltage during flight. The voltage should remain above 43.5 V, even when operating at Maximum Take-Off Mass (MTOM).

In the event of a crash, the drone typically disarms itself. However, if the rotors are still spinning, the pilot should attempt to activate the Motor emergency stop (by pressing the C and D buttons simultaneously), even if the 'Communication Lost' message is displayed.



Never approach an armed drone!

Mandatory Remote identification with Dronetag

For security reasons, remote identification of drones is mandatory in the United States and the European Union. All drones must be equipped with a Remote Identification device to locally transmit information about the operating drone.

The M12 drone comes equipped with a Dronetag DRI Remote ID module and complies with the regulatory requirements of the European Union¹ and the United States².

The Remote ID of your drone is its serial number, which is broadcast from the device during flight. The drone's system prevents takeoff if the Remote ID is not functioning.

The **RID icon** shows the operational status of the Remote ID system. If the icon is green, the Remote ID is broadcast correctly.



If the RID icon is red, it indicates that the Remote ID broadcast is not functioning properly.

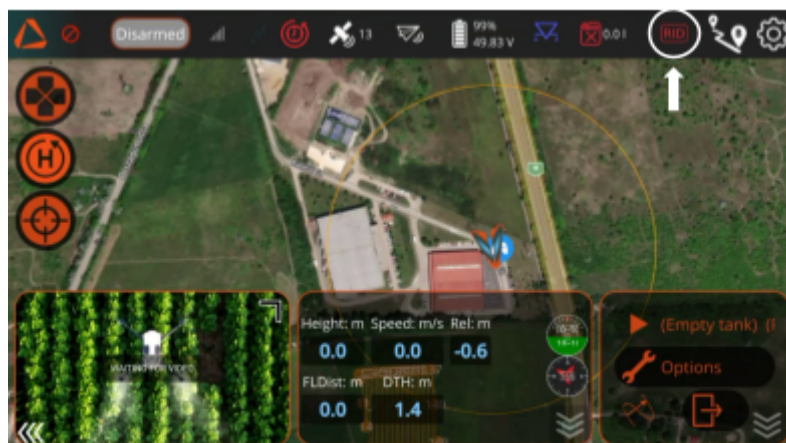

¹ Commission Implementing Regulation (EU) 2019/947 (<https://eur-lex.europa.eu/legal-content/EN/TXT/?uri=CELEX%3A32019R0947>)

² 14 CFR Part 89 – Minimum Performance Requirements for Standard Remote Identification of Unmanned Aircraft (<https://www.ecfr.gov/current/title-14/chapter-I/subchapter-F/part-89>)

By clicking on the icon, you can check the health of the systems providing the necessary data for the Remote ID module.

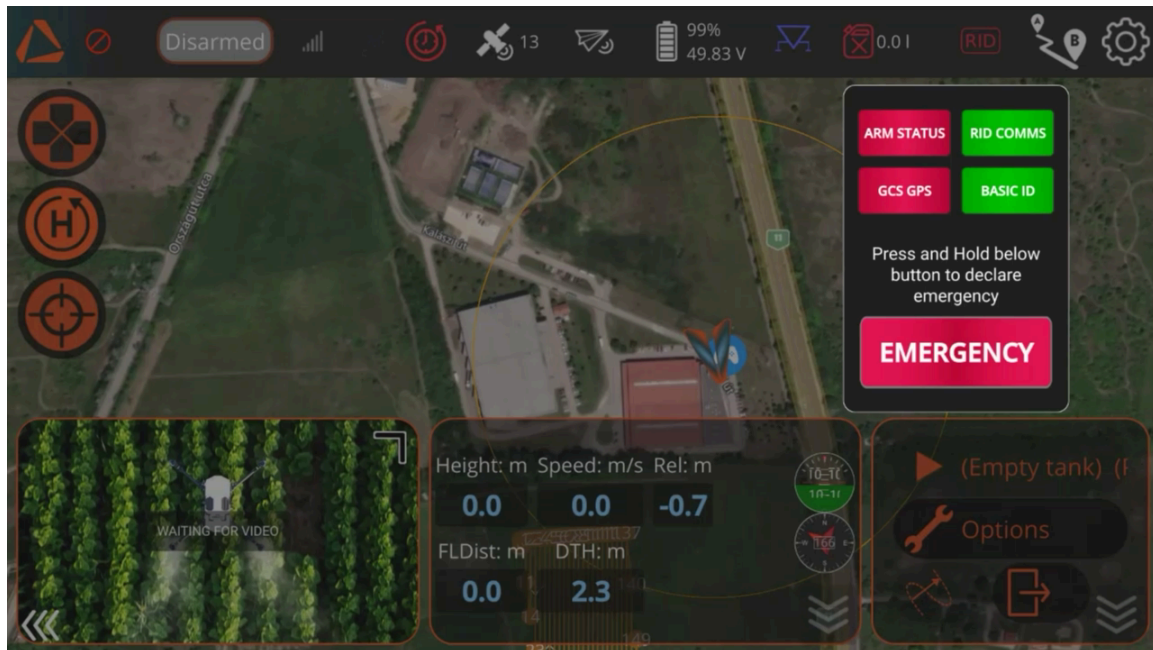

The **ARM STATUS** field provides feedback about the proper functioning of the location source hardware and software of the drone. In the case of a malfunction, this icon will turn red, and consequently, the Remote ID icon will also turn red, indicating a malfunction in the Remote ID system. The drone will also provide an error message stating that the Open Drone ID has encountered a problem (e.g., not receiving a location message).

The **GCP GPS** field provides feedback about the proper functioning of the Transmitter radio GPS (hardware and software). In the case of a malfunction, this icon will turn red, and consequently, the Remote ID icon will also turn red, indicating a malfunction in the Remote ID system. The drone will also provide an error message stating that the Open Drone ID has encountered a problem (e.g., not receiving a location message).

The **RID COMMS** field provides feedback on the proper connection between the Remote ID module and the drone.

The **BASIC ID** field should always be green, indicating that the drone's serial number has been set up as Remote ID and is broadcasting.

If the Remote ID system experiences an error due to insufficient GPS coverage on the drone or the remote controller, or a hardware malfunction, the drone prevents arming.



The drone continuously monitors the Remote ID functionality **from takeoff to shutdown** and provides a **notification of any malfunction or failure** in the top bar of the ABZ Control application. If the Remote ID system detects an error during flight, the RID icon will turn red, and the drone will provide an error message stating that the Open Drone ID has encountered a problem (e.g., not receiving a location message).

If the Remote ID system experiences an error during operation, the unmanned aircraft is no longer broadcasting the message elements of the standard Remote ID.

The pilot must³ land the unmanned aircraft as soon as practicable.

³ in accordance with 14 CFR Part 89 (Minimum Performance Requirements for Standard Remote Identification of Unmanned Aircraft: <https://www.ecfr.gov/current/title-14/chapter-I/subchapter-F/part-89>)

Declaring an Emergency

In the Remote ID interface, the pilot can click on the **Declare Emergency** button. To declare an emergency, you need to **press and hold the button for 3 seconds**. This function may be employed in situations such as loss of control, potential threats to persons or property, or in other emergency scenarios, at the pilot's discretion.



When an emergency is declared, the drone will broadcast the emergency status. To clear the emergency, press and hold the same button (which now displays the text '**Clear Emergency**') for 3 seconds.



Remote Controller

The M12 is compatible only with the controllers provided by ABZ Innovation with specialized ABZ Control software. All firmware/software combinations are compatible with the drone.

The available remote controller unit:

- ABZ Innovation MK15

Other devices or applications are not compatible for controlling the drone and, therefore prohibited to use with the drone.

The MK15 remote controller is an Android operation system-based device, with an integrated system for communicating through radio signals with the drone. It runs the **ABZ Control** application to control the drone and let the pilot access all telemetry data and advanced flight planning.



If the remote controller is turned off, you can check the battery charge of the remote controller by a short push of the power button. The blue LEDs indicate the charge level. The single LED in front of them gives feedback about the connection between the drone and the remote controller. When the LED is green, the drone and the remote controller are connected.

To switch on the remote controller, push the power button once briefly and then once more for a longer duration (until you hear the system's sound signal).

You can only charge the remote controller when it is powered OFF and only with the supplied fast Charger. The RC cannot be charged while working.

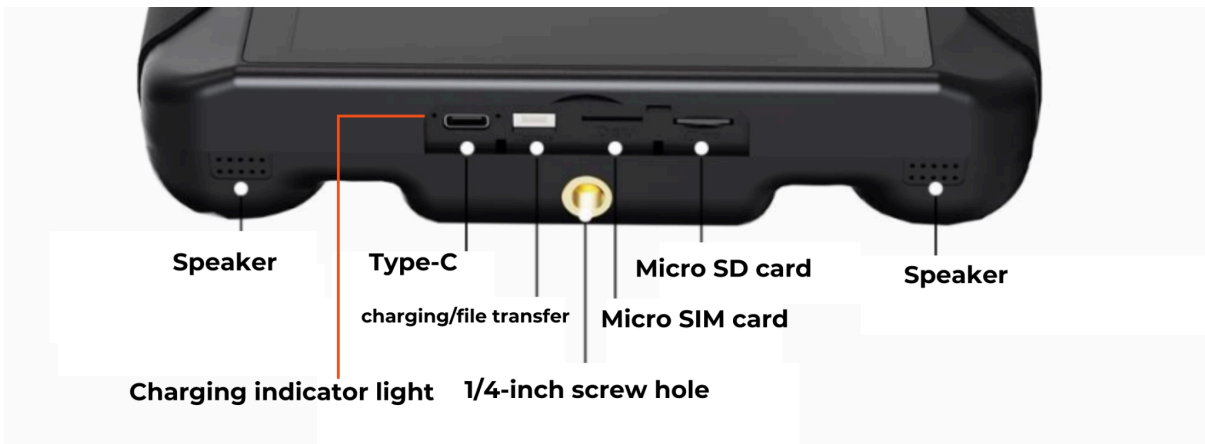

1. Connect the remote controller to the fast charger (connector Type-C) and plug it into the power supply.
2. The charging indicator lights are red when the ground unit is charging.
3. The charging indicator lights are green when charging is finished.

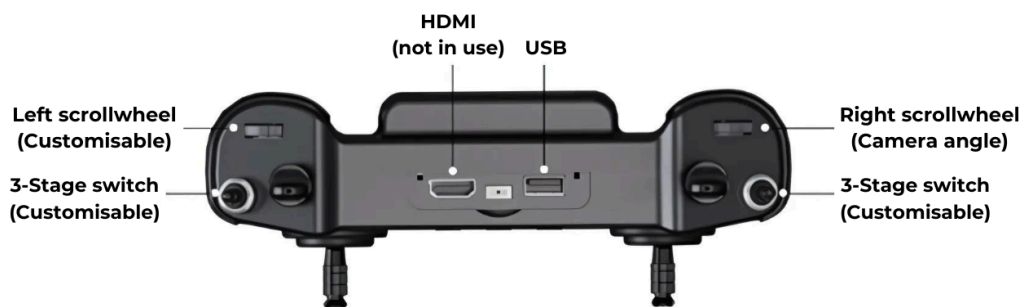

If you push the power button once short, the screen will turn off (power saving mode). If you push the button for 1 second, you can choose between the options of powering off the remote controller or taking a screenshot.

Remote Controller Settings

You can access the Android navigation bar by swiping down from the top of the screen or swiping from the right side of the screen.

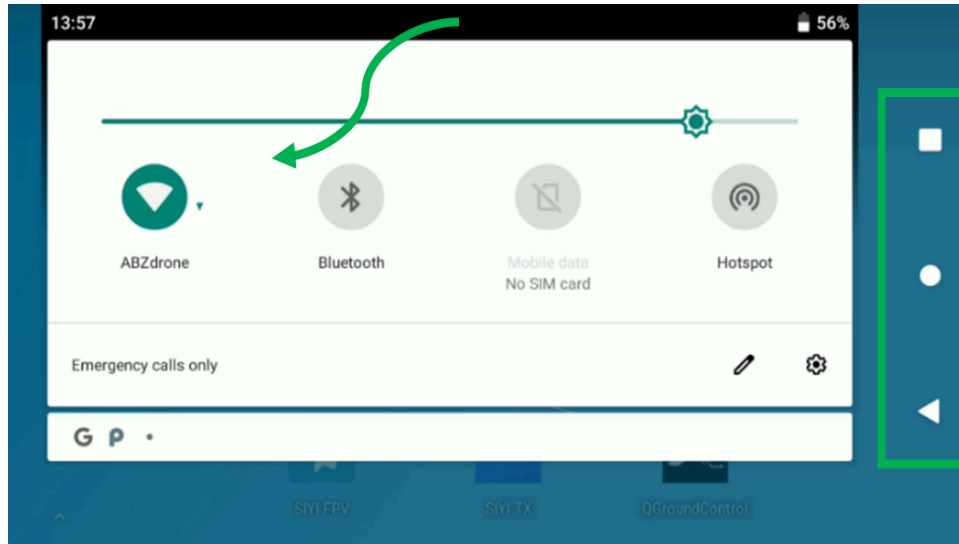

The rectangular icon allows you to switch between applications. The circular icon takes you to the main screen. The triangular icon lets you go back to the previous screen (note: this function is not supported in ABZ Control).

The remote controller battery status is displayed in the Android menu (by swiping down from the top of the screen).

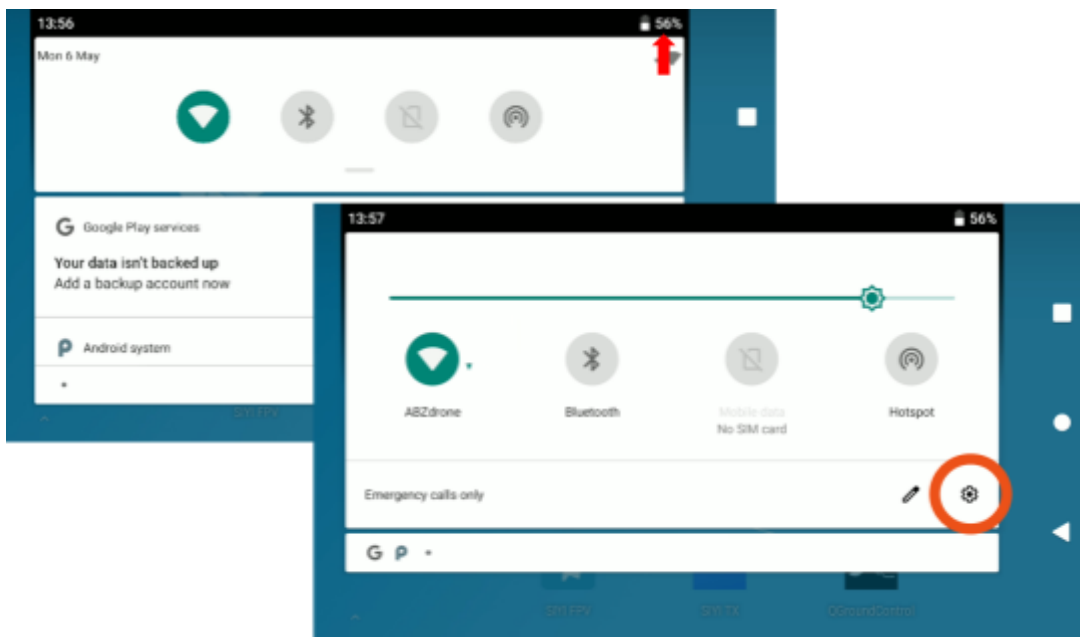

Set the **display brightness** and **sound volume** always according to environmental conditions (light conditions and noise level)! Setting the display brightness and sound volume is always accessible (even when operating the ABZ Control software) from the basic Android menu, swiping down from the top of the touch screen once, where the general Android quick menu appears.

Swiping down from the top of the touch screen once more, the slider for the display brightness setting appears:

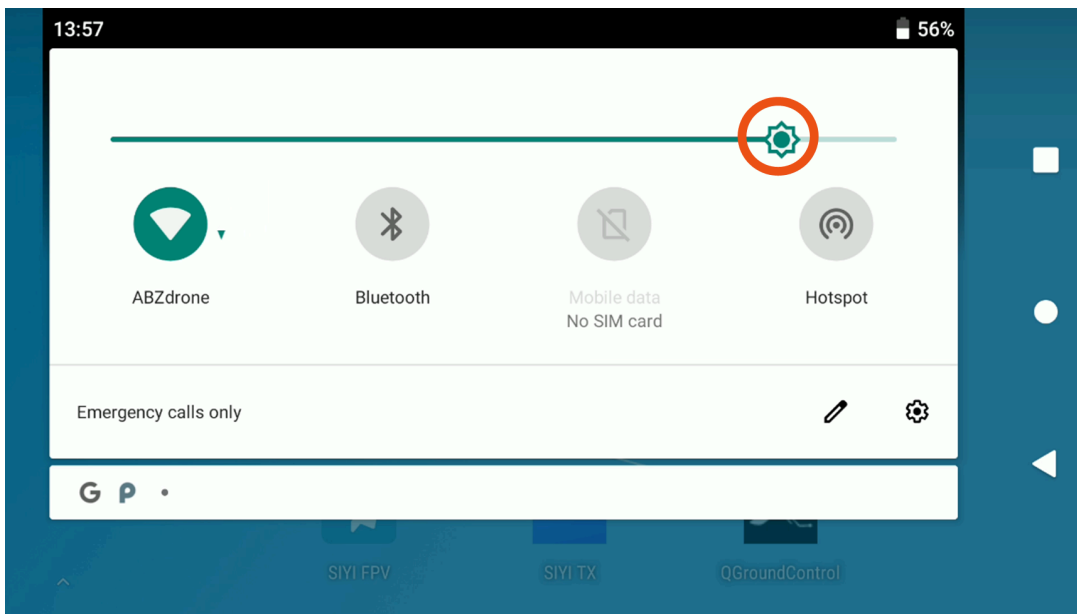

Click on **Settings** (gear icon) then scroll down to the Sound menu and tap on it to show the sliders for volume control functions.

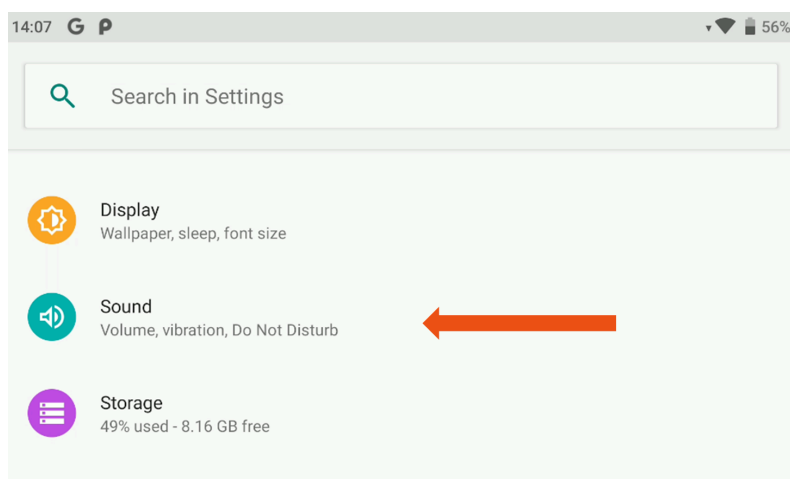

Media volume controls the ABZ Control application’s alerts and information volumes. **We highly recommend keeping it set to maximum volume at all times.**



Network settings

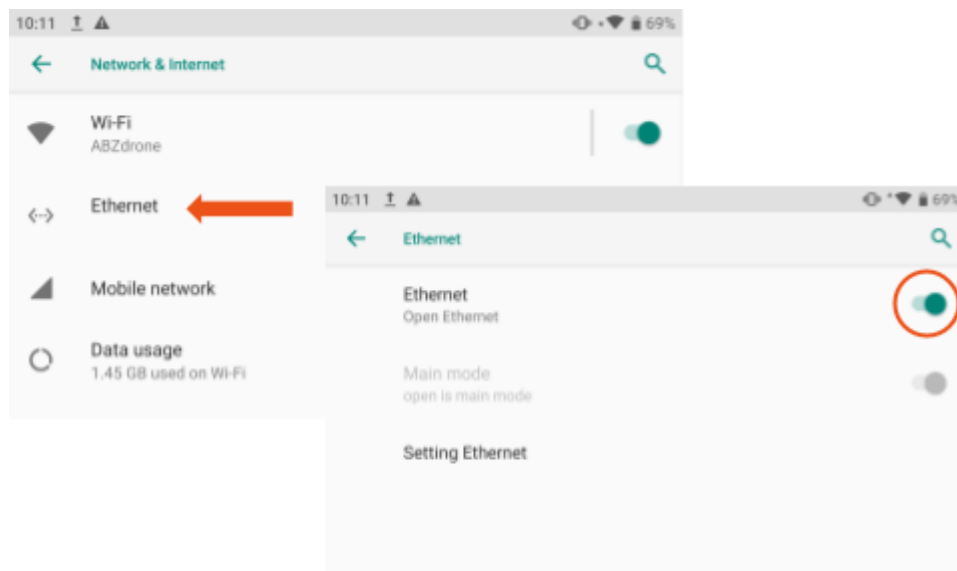

To ensure the proper functioning of the ABZ Control application, the Ethernet connection must always be turned on. This setting is available under *Android Settings > Network & Internet*.

Internet connection

The remote controller can access the internet via Wi-Fi or Bluetooth connection, e.g. shared from a router, mobile phone, tablet, or laptop.

These options are available in the Android's Settings menu (by swiping down from top), by long pressing the Wi-Fi or Bluetooth icon, or by tapping the gear icon.

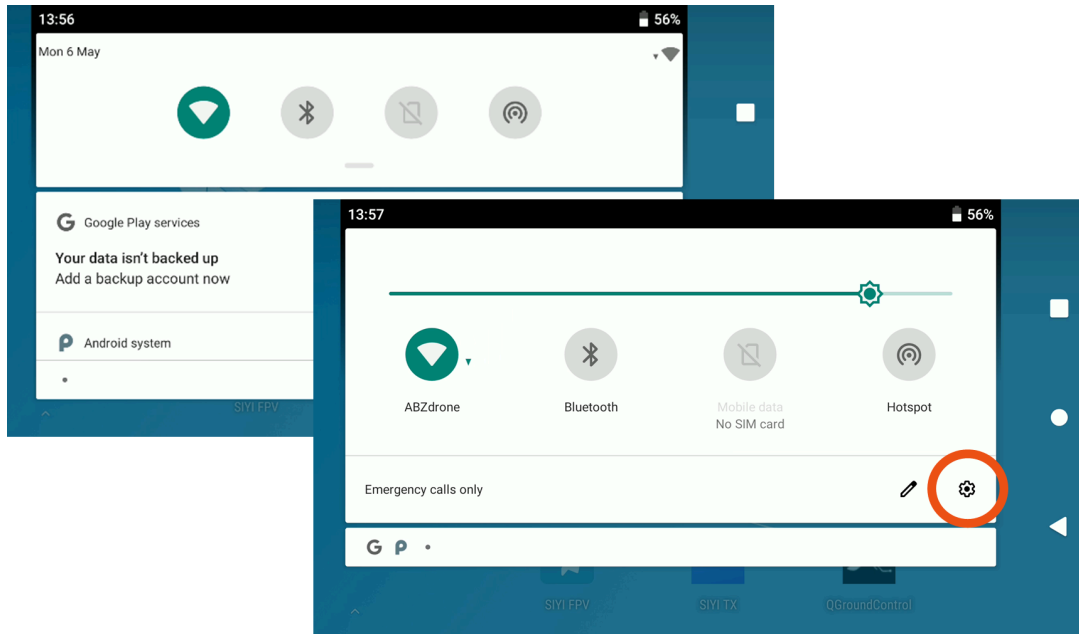

In the submenu the function can be switched on/off and the available devices can be connected. Wi-Fi only works on 2.4GHz networks. If the controller does not recognize the Wi-Fi from your mobile device, using Bluetooth connection for internet access is recommended.

To set up the Bluetooth connection for internet access:

1. Turn off Wi-Fi on the controller.
2. Turn on Bluetooth hotspot / internet sharing on your mobile device.
3. Turn on Bluetooth on the controller and pair the two devices.
4. If your device is connected to the controller, you need to set up the internet connection.
5. Tap on the gear icon next to the device name, then turn on the Internet access.

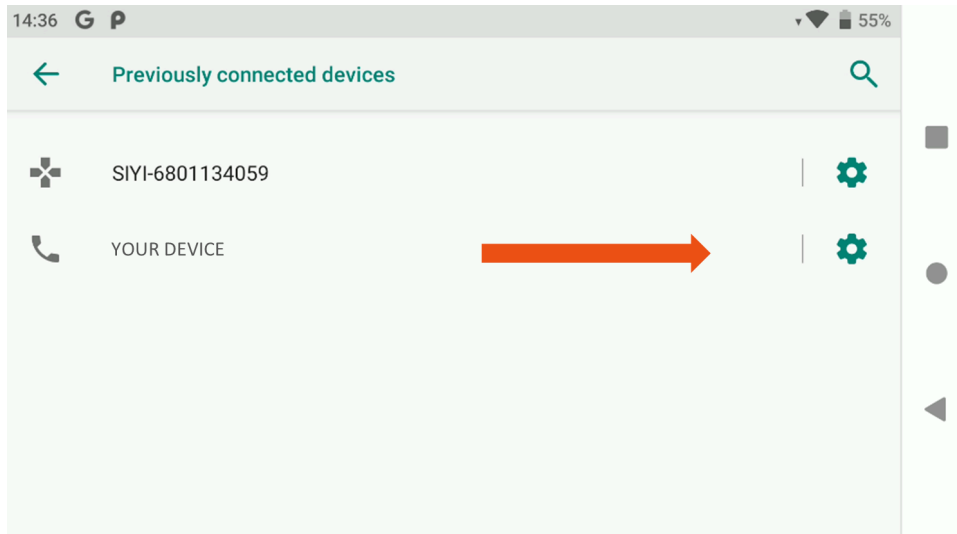

Controlling the drone

It is only permitted to operate the drone in full compliance with this entire operator's manual and specifically the checklists.

Manual flight commands - switching flight modes to choose manual flight control:

- **Manual (Loiter) flight mode: A button** – (GPS-based) the flight must be controlled manually with the sticks. If both sticks are fully released, the drone will stop and hover at the actual GPS coordinated position.
- **AltHold flight mode (WITHOUT GPS positioning):** By default, this manual flight mode is **disabled** on the RC. To enable it, go to *ABZ Control > Settings > ABZ Flight > Advanced*. Once enabled, AltHold mode can be activated with the **C button**.

In this mode, flight, braking, and stopping must be controlled manually with the sticks. The drone does not maintain its position, and the pilot must counteract wind forces. The drone maintains altitude using only its barometric pressure sensor, so the pilot must pay attention to altitude changes caused by atmospheric and weather conditions.

Automatic flight commands - switching flight modes to start automated flights:

Auto flight mode: slider on the screen – (GPS based) the drone will fly the mission uploaded to the drone (created by Mission Planner application or created by ABZ Control on the remote controller). Always start the drone manually and fly to a safe height before switching to Auto flight mode.

Return To Launch flight mode: B button – (GPS based) the drone will fly the shortest way to the launch position (if not changed manually, it is the same as the take-off position) at the specified altitude (Settings/Safety/Return to Launch) and then land itself.

Every automated flight can be interrupted at any time, by the pilot's command to switch back to manual flight mode (**Manual (Loiter)** or **AltHold**).

Emergency stop: In case of emergency, push the C button and D button simultaneously for at least 1 second. The motors will stop immediately, and the drone will crash into the ground.



The drone's pitch and roll angles, turning radius, climb, and descent speeds are limited by firmware in order to ensure safe flight. The pilot can safely fly the drone within all possible pilot inputs, no extra limitations are needed to implement manually.

- **Takeoff:** Switch to “Armed” mode by pushing the left control stick fully to the down-right position until “Armed” is shown on display, then release.
- After the motors are started and **have reached operating speed**, fly the drone manually using the left stick in **Mode 2** (default), and **take off to a safe height (at least 3 m/9.8 ft)**.
- **Land:** Manually control the descent speed and slow it down before reaching ground.

After landing, switch to „**Disarmed**” mode by pushing the left control stick fully to the down position until „Disarmed” is shown on the display and the motors are completely stopped, then release.

Make sure to release the stick after arm immediately, otherwise the system will detect your action as accidental and switch back to the mode previously selected.

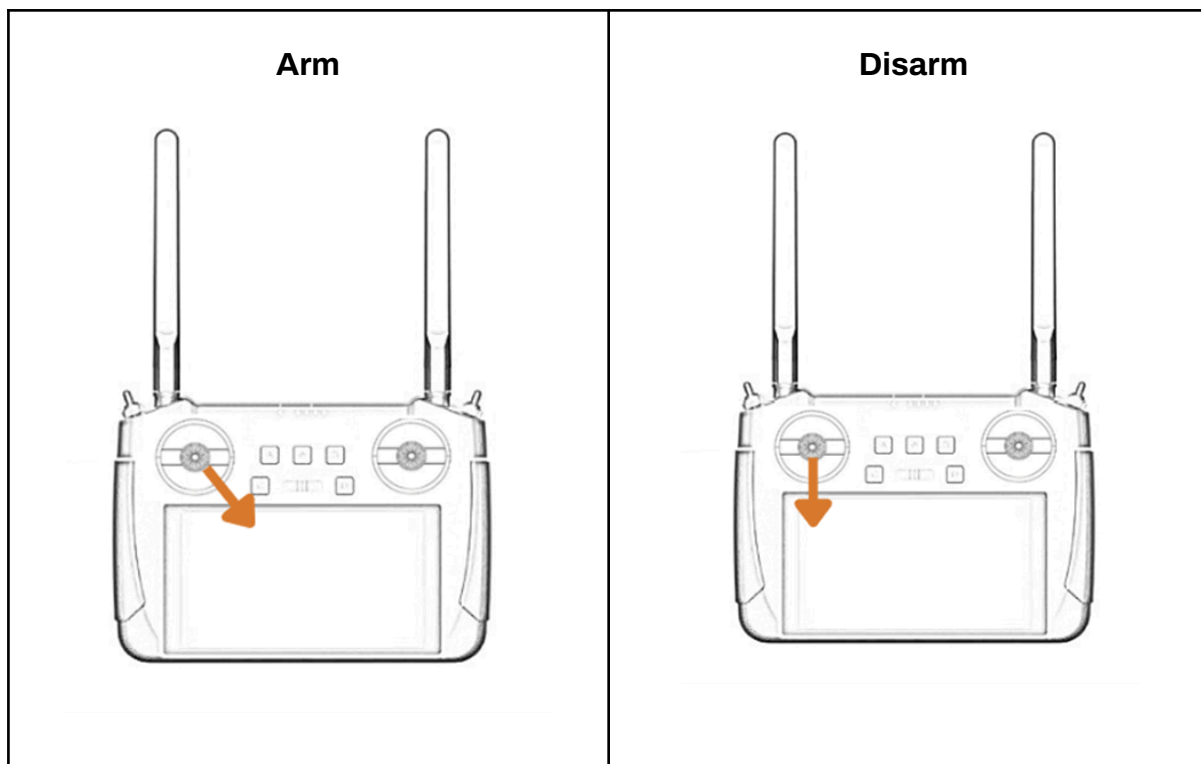

When you arm or disarm the drone, a large orange text appears on the screen, notifying you of the drone's status change. If audio is enabled, a voice notification will announce the same:



Default control (mode 2)

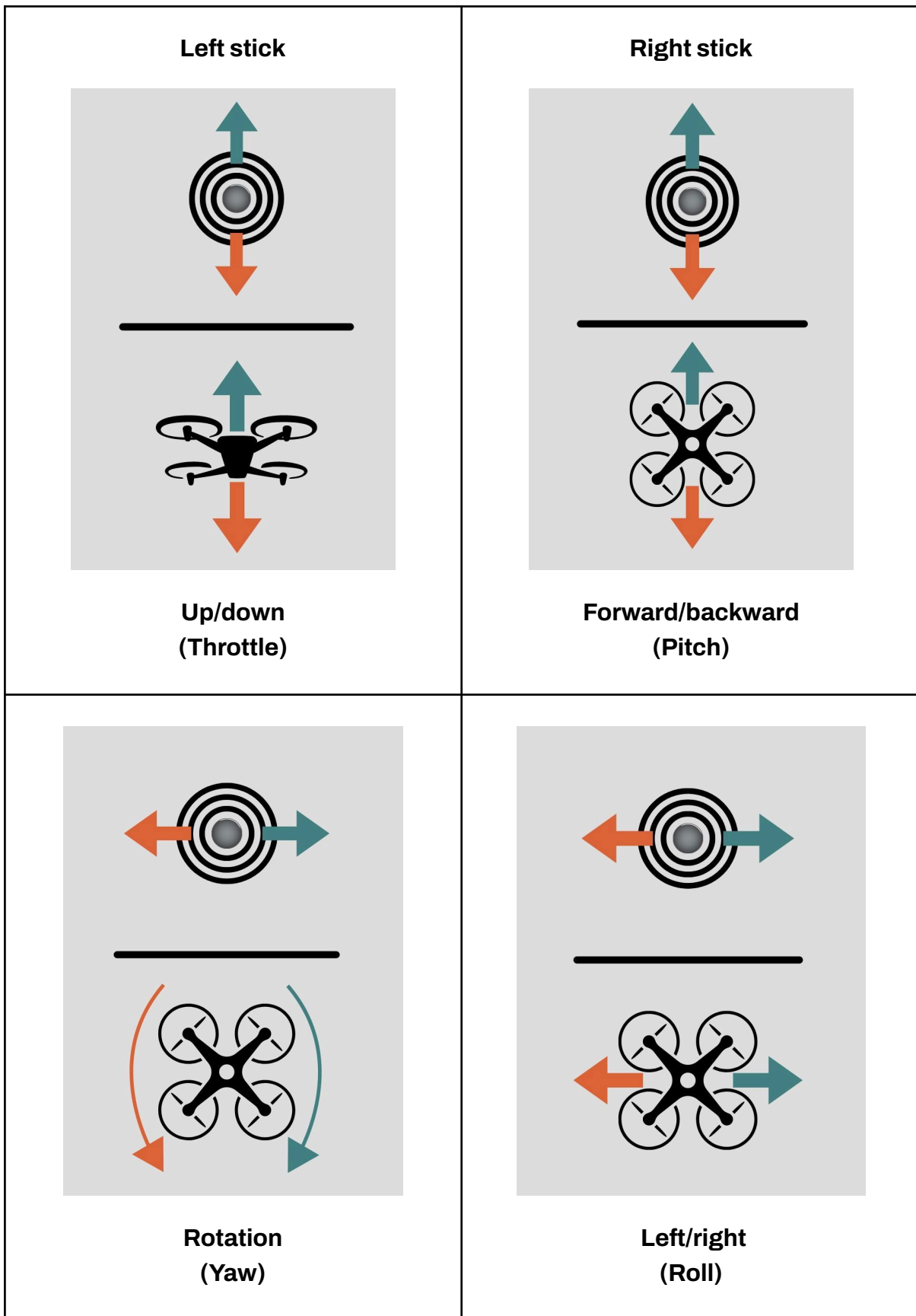

ABZ Control Software Overview

The M12 is compatible only with the controllers provided by ABZ Innovation with specialized ABZ Control software. Other devices or applications are not compatible for controlling the drone and, therefore prohibited to use with the drone.

No software update is needed before and during operating the drone, future updates are only optional. Any future software updates will not affect the control and flight functions. Software update procedures are explained and guided in the documentation of the update package. All information and files are available at: abzinnovation.com/updates. Please check this website if you are looking for software or firmware update options.

Start the ABZ Control flight control and planning application by clicking on its icon on the home screen.

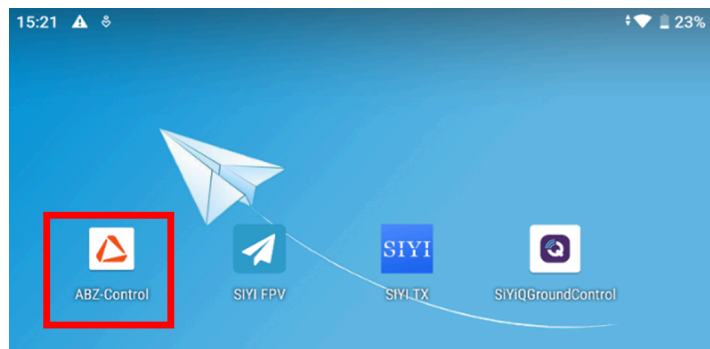

After starting the ABZ Control application, you will receive a pop-up window with the message: Allow ABZ Control to access USB to UART Controller. Click on OK.

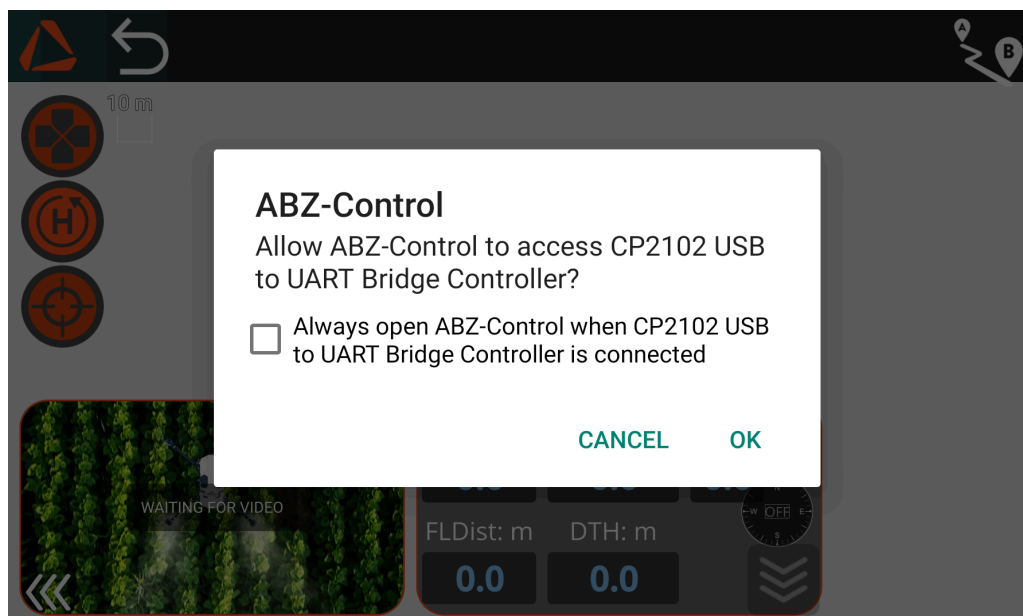

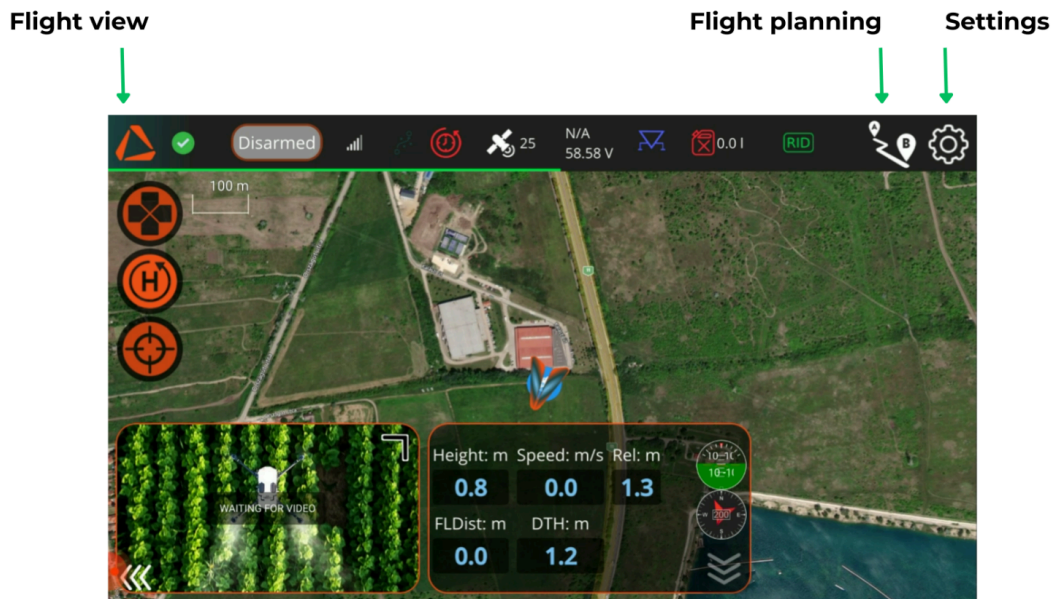

After launching the application, the following screen will be displayed. In the top menu bar, you will find icons representing the main views. In the left corner, the ABZ Innovation icon navigates to the Flight view.

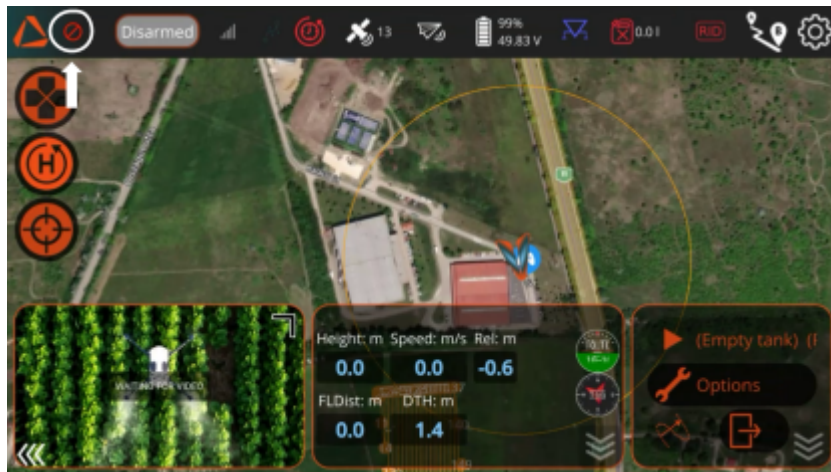

In the right corner of the top bar, you can access the Settings (gear icon) and the Flight Planning view (A to B icon).

After powering on and connecting the drone, you will see status icons at the top, including: Vehicle Messages, OBA Status, Connection Status, GNSS Status, Drone Battery Status, Payload Status, Virtual Tank Status, and Remote ID Status.



On the left side of the top bar, a red no-entry sign indicates that the drone is still preparing its systems for flight. If the icon changes to a green check mark, the drone is ready and can be armed. (Below the messages , you can check the pre-arm check messages and any potential error messages.)

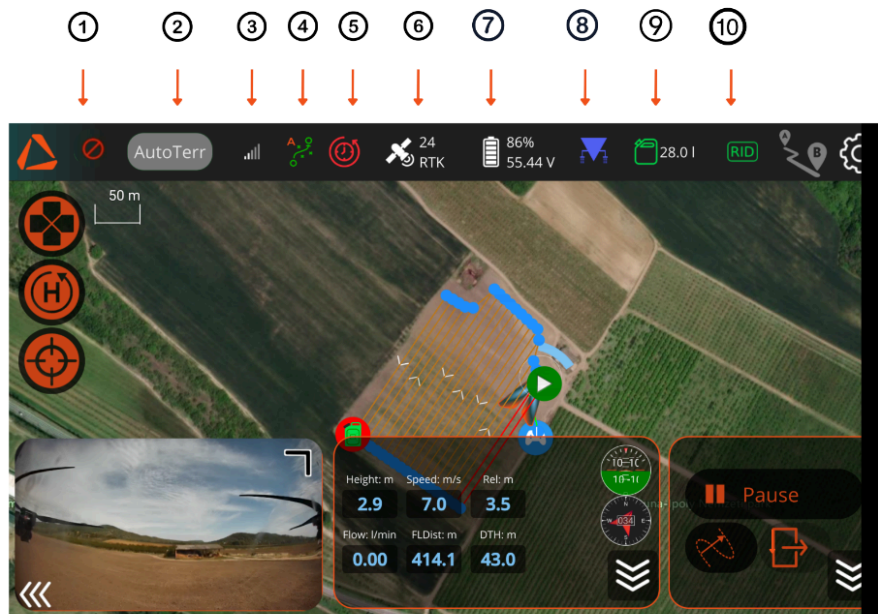

- | | |
|--|--|
| <p>① Systems ready:</p> <ul style="list-style-type: none"> Not ready to fly Ready to fly <p>② Flight mode and altitude hold method</p> <p>③ Signal strength </p> <p>④ Obstacle avoidance (OBA) status</p> <ul style="list-style-type: none"> OBA inactive OBA active (manual mode) OBA active (automatic mode) <p>⑤ Vehicle messages</p> <ul style="list-style-type: none"> New messages available No new messages available <p>⑥ GNSS status</p> <p>Above: Number of satellites </p> <p>Below: RTK connection feedback</p> <p>⑦ Drone Battery status</p> <p>Above: charge percentage </p> <p>Below: Battery Voltage </p> | <p>⑧ Payload status (relevant only for L-series drones)</p> <ul style="list-style-type: none"> Sprayer OFF Sprayer ON Spreader OFF Spreader ON Trichogramma OFF Trichogramma ON <p>⑨ Remote ID (RID) Status</p> <ul style="list-style-type: none"> RID healthy RID unhealthy <p>⑩ Tank status (relevant only for L-series drones)</p> <ul style="list-style-type: none"> The tank is empty The tank is filled. The number indicates the remaining amount. |
|--|--|

The RID icon shows the operational status of the Remote ID system. If the icon is green, the Remote ID is broadcast correctly. By clicking on the icon, you can check the health of the systems providing the necessary data for the Remote ID module. For further information regarding Remote Identification, see [Mandatory Remote identification with Dronetag](#) (page 14).



In the event of a Remote ID system error caused by insufficient GPS coverage on the drone or the remote controller, or by a hardware malfunction, the drone prevents arming!

Next to the drone battery icon, you will see the charge percentage and battery voltage. During the flight, you must continuously monitor the battery voltage, which should remain above 43,5V, even when flying at the Maximum Take-Off Mass (MTOM).

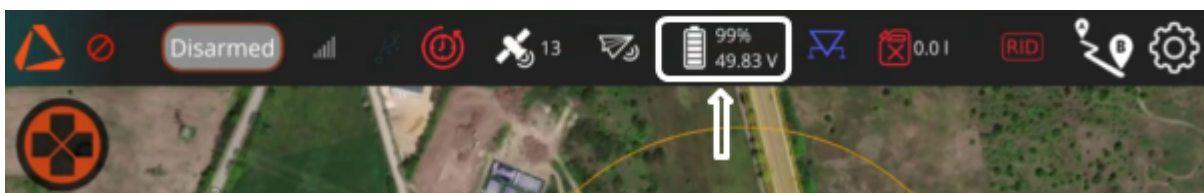

The state of the drone battery should also be monitored before the flight using the charging indicator LEDs on the battery. We recommend starting the flight with a minimum of 80% battery charge.

In the Flight status bar, you can see information about the altitude hold method (Follow terrain with LiDAR or Relative) and the actual flight mode of the drone. (Follow terrain mode applies only for drones equipped with LiDAR!)







It can show the following statuses:

- Disarmed
- ManualTer – Manual (Manual (Loiter)) Follow terrain mode (Optional)
- ManualTerRel: Manual (Manual (Loiter)) – Relative mode
- Auto mode – Forest mode
- AutoTerr: Auto mode – Follow terrain (Optional)
- AutoRel: Auto mode – Relative mode
- RTL (Return to Launch mode)

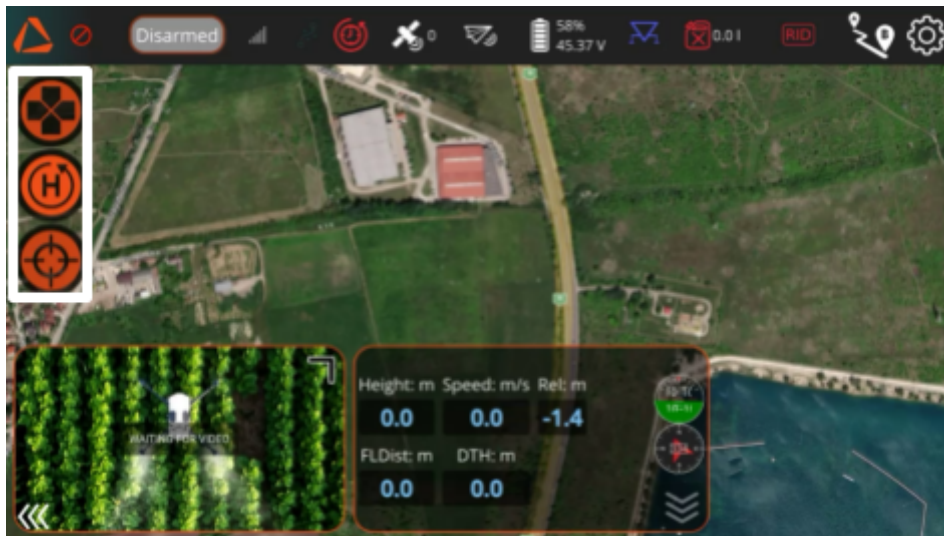
Only fly the drone if the green check mark is visible, and the **Manual (Loiter) flight mode** is selected.

On the left side, you will find three Flight function buttons:



- With the cross button,  you can change the flight mode. You can choose between **Manual** and **Altitude Hold** (if enabled under Settings > ABZ Flight > Advanced).
- With the  Home button , you can initiate **RTL** (Return to Launch) flight mode. The drone will then immediately return to the launch point—without asking for confirmation—based on the settings defined under **Settings > Safety > Return to Launch**.
- With the target button  , you can choose what the map should be centered on: your **Mission**, your drone (**Vehicle**) or the **Remote Controller**.



In the Flight view, with a mission uploaded to the drone, you will see three windows at the bottom of the screen: the **Camera View**, the **Telemetry Window**, and the **Operation Window**. By clicking on the white arrows (1), you can hide the windows.

The Camera Image has three possible views: hidden, default (minimal with full-screen map), or full-screen (with minimal map). You can toggle between these view options by clicking the black corner (2).

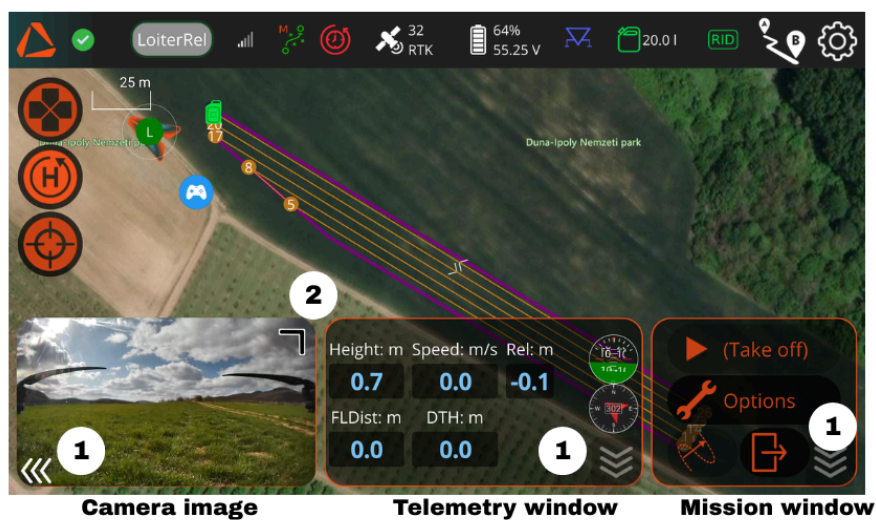

You can adjust the camera angle with the right scrollwheel on the remote controller.

The **Telemetry Window** displays real-time telemetry data, including operational information and drone measurements.

In the telemetry window, you can monitor the following data during flight:

- **Height** → The current height from
- **Rel** → The relative altitude from the takeoff point.
- **Speed** → The current speed of the drone.
- **FLDist (Flight Distance)** → The distance that the drone has flown from the takeoff point.
- **DTH (Distance from Home)** → The distance from the Home point (takeoff point).
- **Flow**: the actual spraying flow in l/min (Relevant only for L-series drones)

If a mission was uploaded to the drone, the **Operation window** displays the upcoming steps for the pilot and provides access to essential functions throughout the automatic flight.

To start a mission, you will need to define a fluid level for the virtual tank, arm the drone, and take off manually. After these steps, the Mission Start button becomes available.

(For further information about flying a Mission, see [Starting the mission](#) (page 72).

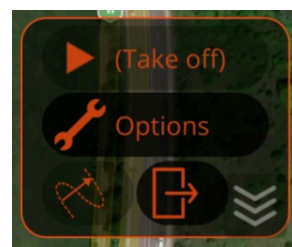

If the drone is in **Auto** **Mission** mode, this button will change to **Pause** Mode. When you click on Pause, the drone switches to Manual (Loiter) Mode.



During flight, in the Operation window:

- Use the **Options button (1)** to change the Mission parameters (speed, height and spacing) after pausing the mission.
- Use the **OBA button (2)** to manually declare an obstacle. (For more information on [obstacle avoidance](#), see page 50.)
- Use the **Exit mission button (3)** to clear the mission from the drone.

Settings

In the **Settings** menu, you can change the user interface settings (e.g., language or units of measurement), configure the Failsafe and Mission-related behavior of your drone, set up the Obstacle Avoidance system, manage the shapefiles used during planning, configure the RTK correction, and adjust the default behavior of your drone. To access the Settings, tap the gear icon in the top-right corner of the screen.



In the General menu, you can configure various settings, including the default units used for measurements in the ABZ Control interface and the provider of the online map displayed in the background of the Flight view.

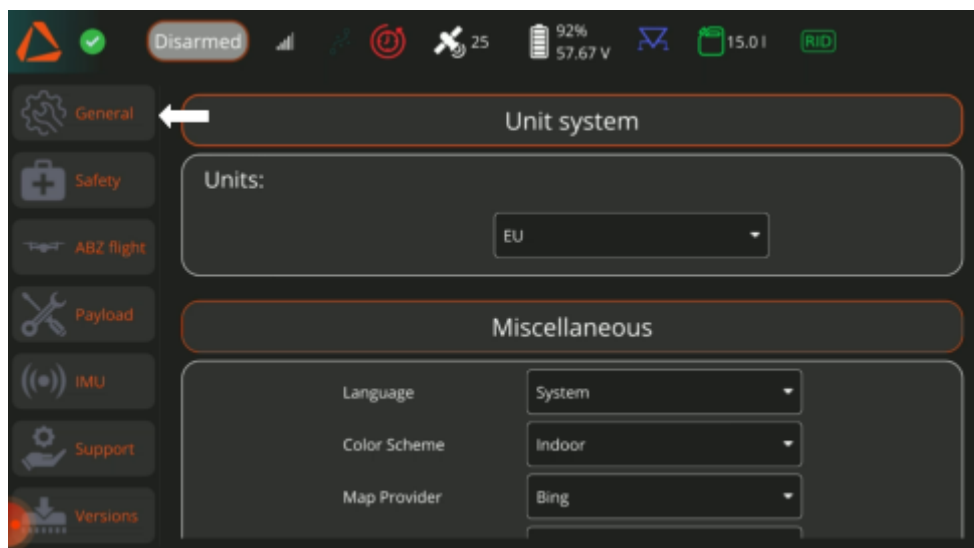

Under the Camera View section, you can see the camera type used by ABZ Control. The default setting is FPV.

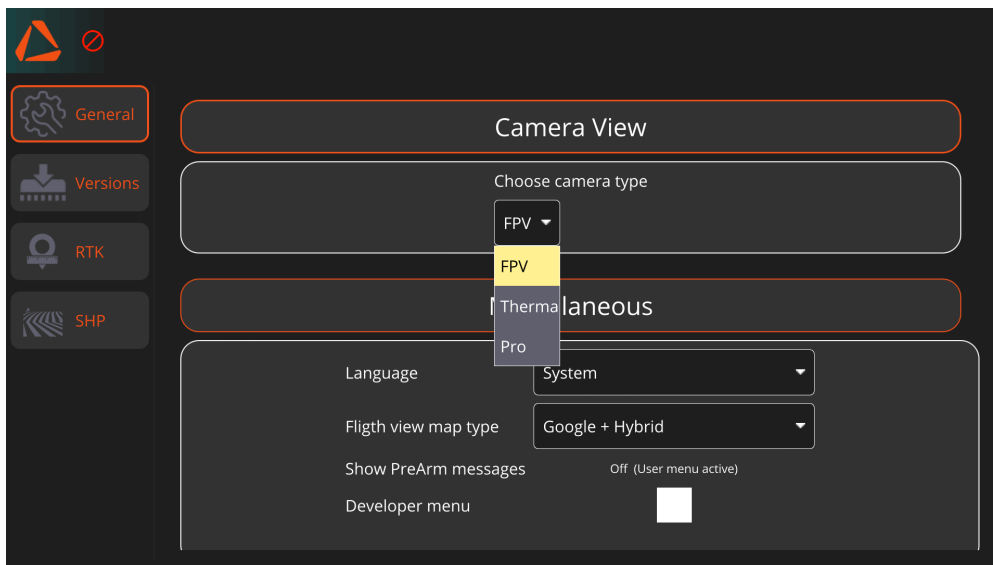

You can save the telemetry log files of your flights by checking in the Save log after each flight. The data will be saved to the folder under *ABZ Control > Telemetry* folder.

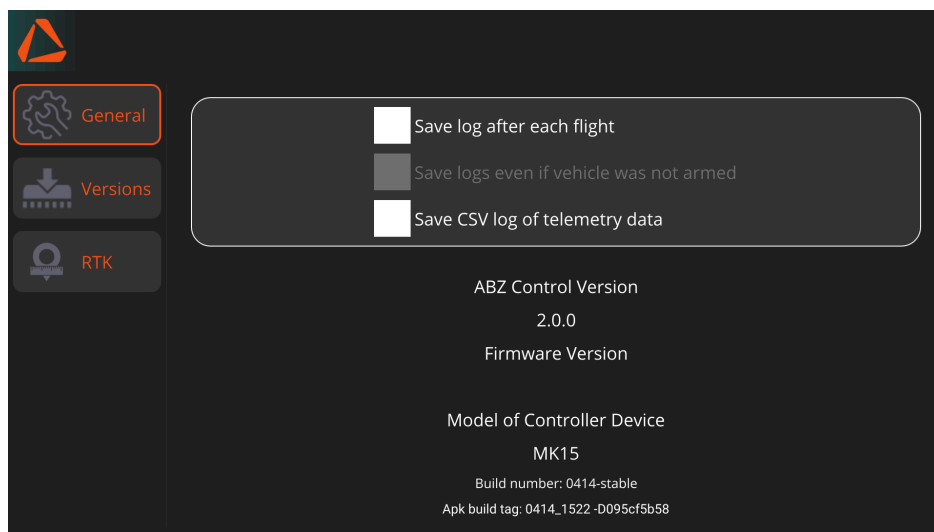

The current software version of your drone is displayed at the bottom of this page. If you contact our Support Center with an inquiry regarding your drone, you will be required to provide this information. The same details are also accessible via the *Settings > Versions* menu.

Safety – Setting up FailSafe

When using a UAS, unexpected events may occur that require intervention. The FailSafe settings are required by law, primarily to prevent personal injury and property damage.

Under *Settings > Safety*, always check and configure the FailSafe settings before every new flight or mission.

- **General failsafe triggers:** you can set what the machine should do in case of losing the remote controller's signal
- **Return to Launch:** set parameters for automatic return to home
 - Specify if current or specified altitude is desired.
 - Specify if the drone should wait and loiter above the takeoff position before landing.
 - Specify the final land stage descend speed (limited by the drone's limitations).
 - Return speed: decide the speed at which the drone flies in Return-to-Launch mode.
- **Return to Mission:** Configure how the drone returns to an interrupted mission. Upon interruption, the drone will navigate back to the interruption point using the shortest available route.
 - Specify whether the **current altitude** or a **specified altitude** should be used during the return. By default, the system uses the current altitude.
 - If a specific altitude is defined, the drone will adjust to that altitude before proceeding to the interruption point.
Note: The specified altitude is relative to the home point.
 - Specify the **returning speed** (limited by the drone's limitations)
- **GeoCage:** you can set virtual boundaries that the drone will not fly over.
 - Circle Centered on Home means the drone will stop if it reaches the desired radius from the Home position.
 - Maximum Altitude means the drone will not fly over the desired altitude relative to the takeoff position.For more safety instructions [when you use the Geocage with AltHold](#) flight mode, see page 98.

- **Prearm checks:** Arming checks are meant to check all the functions and systems necessary for arming and flying the drone safely. All the prearm checks listed in this section are essential and mandatory for safe operation; do not change these settings.

You can also configure the drone's heading behavior and flight speed during Return-to-Launch mode. To adjust these settings, go to *Settings > ABZ Flight > Heading behavior during RTL*.

Action functions:

- **None:** the drone does not take any action itself. It remains in the actual flight mode.
- **Land:** the drone lands at the actual position and disarms itself after landing.
- **RTL:** the drone switches to RTL mode, and following the Return to Launch settings, it flies back to the takeoff position, then lands and disarms itself after landing.



RTK configuration

In the **RTK** menu, you can connect to an RTK correction data source to achieve centimeter-level positioning accuracy during flight. You can connect either to:

- an online server server that provides RTK for your drone(Network RTK),
- an **Emlid base station** via **LoRa radio** or **NTRIP**.

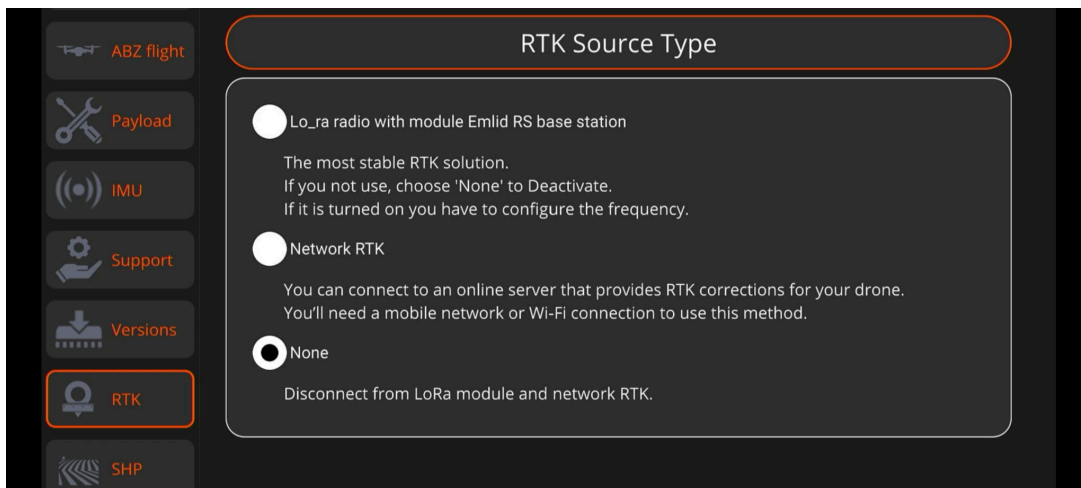

If using an **Emlid RS base station with LoRa**, make sure it is configured to **Output: LoRa**, and that the frequency matches the Base output value specified in the Emlid flow app. You can also connect to an **Emlid RS base station via NTRIP** using the **Network RTK** option. For the required credentials, refer to the **Emlid Flow app**.

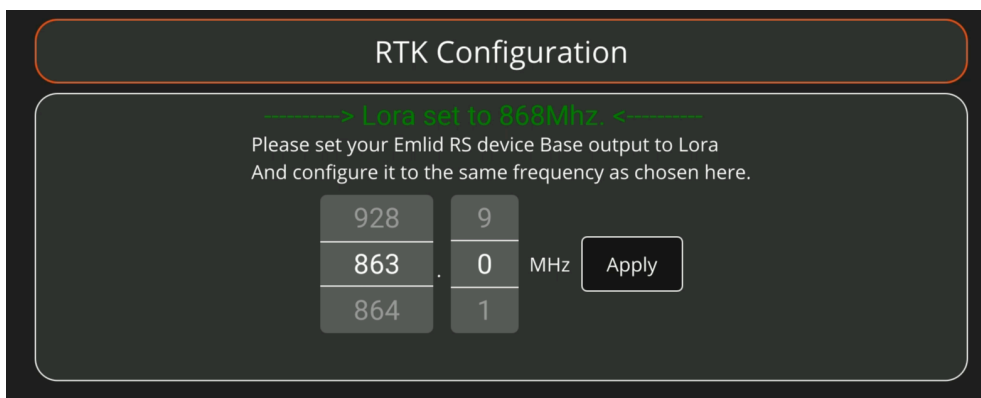

Under **Network RTK**, you can connect to the nearest **Continuously Operating Reference Station (CORS)** via an **NTRIP Caster**. To use this option, you will need an internet connection using your mobile device as a hotspot.

To connect and receive corrections, enter the credentials provided by your NTRIP service provider. For best results, always select the station nearest to your operating location.

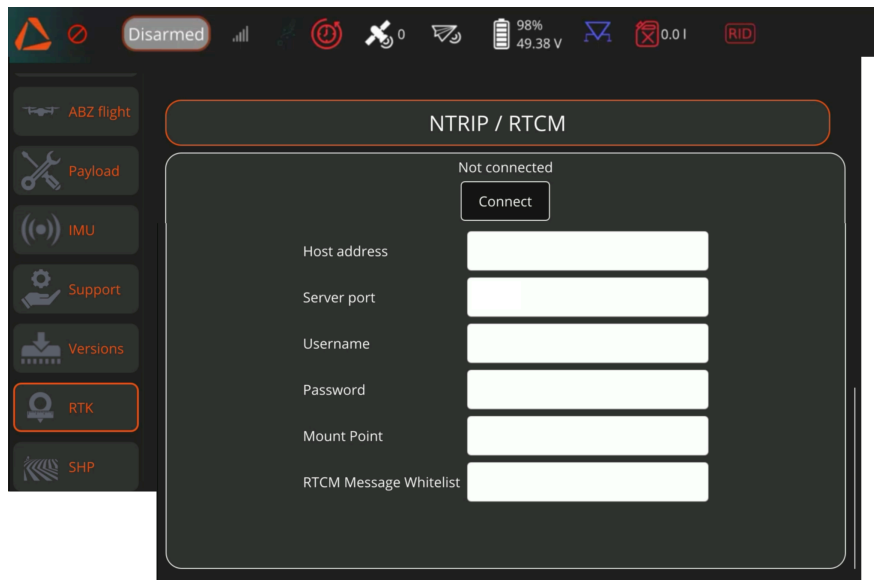

If you choose to fly with an RTK source, the system will only allow you to arm the drone if the correction data is accurate enough to ensure proper drone positioning.

If RTK correction is available and accurate, the “RTK” status will appear next to the GNSS icon in the top bar.

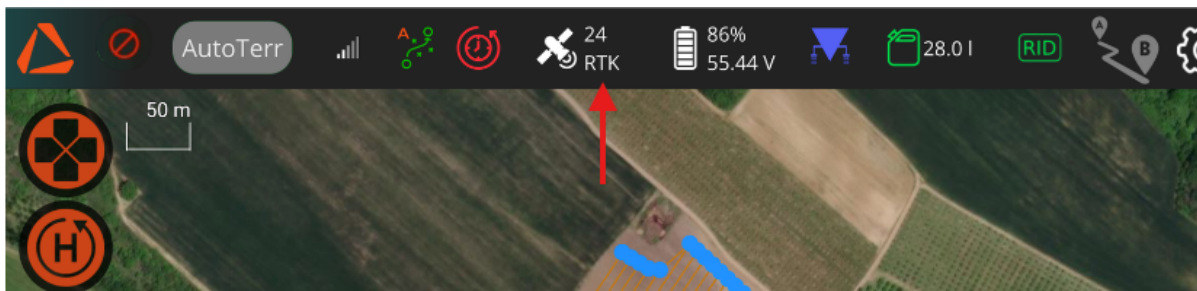

Settings: SHP

In the SHP menu, you can import Point, Polygon, or Polyline shapefiles to [use as a boundary](#), [mission route](#), or [visual guide](#) for mission planning.

To successfully import a shapefile, make sure that:

1. You select a folder **that directly contains** the shapefile folder or a **.zip** archive.
2. The shapefile folder **includes all the required files**: **.shp**, **.shx**, and **.dbf**.
3. The **folder name matches the filenames**.

For further information, see page 78 [[Shapefile Import](#)].

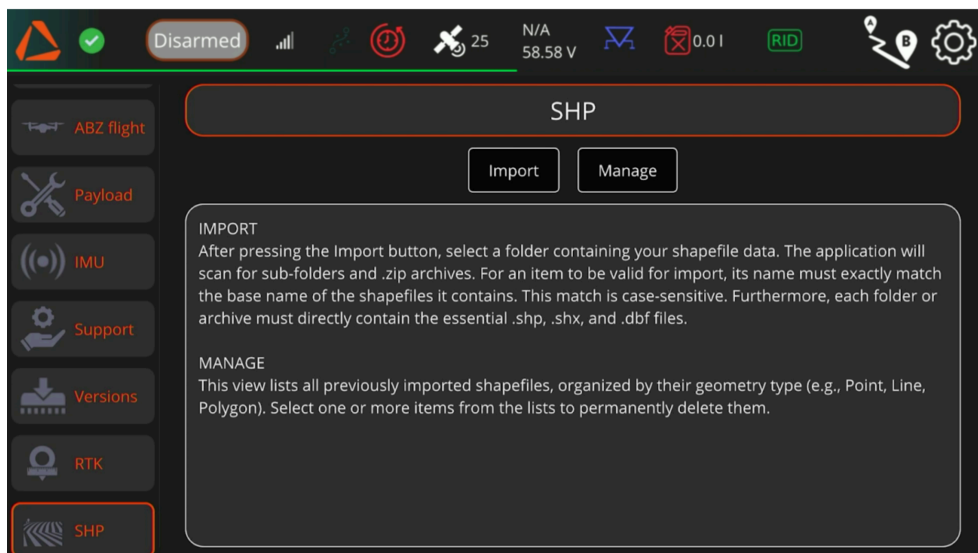

Abz Flight

In the **ABZ Flight** menu, you can enable **Obstacle Avoidance** (only for drones equipped with LiDAR) for both Automatic and Manual (Loiter) flight modes, set the primary height source for the Relative altitude hold method, and configure the drone's mission-related behavior.

In Relative Settings, you can specify the primary height source for the drone when flying without LiDAR measurements. **This setting can only be changed when the drone is grounded and disarmed.** Only use GNSS if flying with an RTK source (e.g., Emlid base station). To learn more about the different altitude control methods, see [“Altitude control”](#) (page 53).

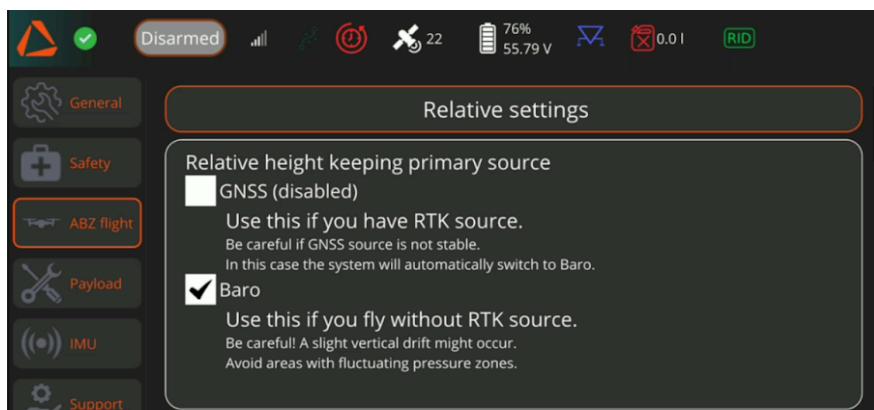

Adjusting the Obstacle Avoidance Options (only for drones equipped with LiDAR)

Under the **ABZ Sense** section, you can enable **Obstacle Avoidance** for both Manual (Loiter) and Auto Flight modes. You can also specify the obstacle sensing distance, which determines how far the drone should stay from obstacles. For more information about the ABZ Sense [Obstacle Avoidance system](#), see page 50.

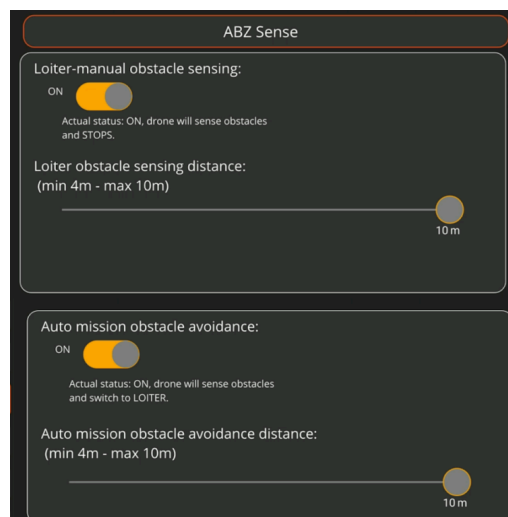

Additional Settings in ABZ Flight

Under the **Additional Settings**, you can configure the drones automatic behaviour during Mission.

- **Emergency Jump:** If **Emergency Jump** is ON, the pilot can manually increase altitude during an automatic flight. Use this function if you see an obstacle that is not in the map, or if the aircraft starts to descend unexpectedly. **Emergency Jump** is OFF by default.

If the Emergency Jump is turned on, the drone will rise as long as the pilot pushes the left control stick up. The other settings (e.g., direction and speed) remain the same as defined in the mission settings. If the pilot releases the stick, the drone remains at the given altitude briefly before returning to the altitude specified for the mission.

- **Mission end action:** you can decide what the drone should do when the mission is completed. You can choose between setting the mode to Land, setting the mode to Manual (Loiter) or returning to launch (RTL).

- **Tank Is Empty Setting:** For M-series drones, ensure this option is set to **Continue Mission**.

- **Heading behavior during RTL:** You can choose the direction the drone should face when returning to its home point. The drone can either maintain its current heading or orient itself toward the home location.

Under the **Advanced** section, you can enable flight mode settings that are initially disabled on the Remote Controller:

- **AltHold Mode:** Allows you to assign Alt Hold to the **C button** and the **virtual Flight Mode function button** (in ABZ Control).
- **Manual Terrain Follow Mode:** Allows you to use the **altitude control method switch (3-stage switch)** in manual flight modes.



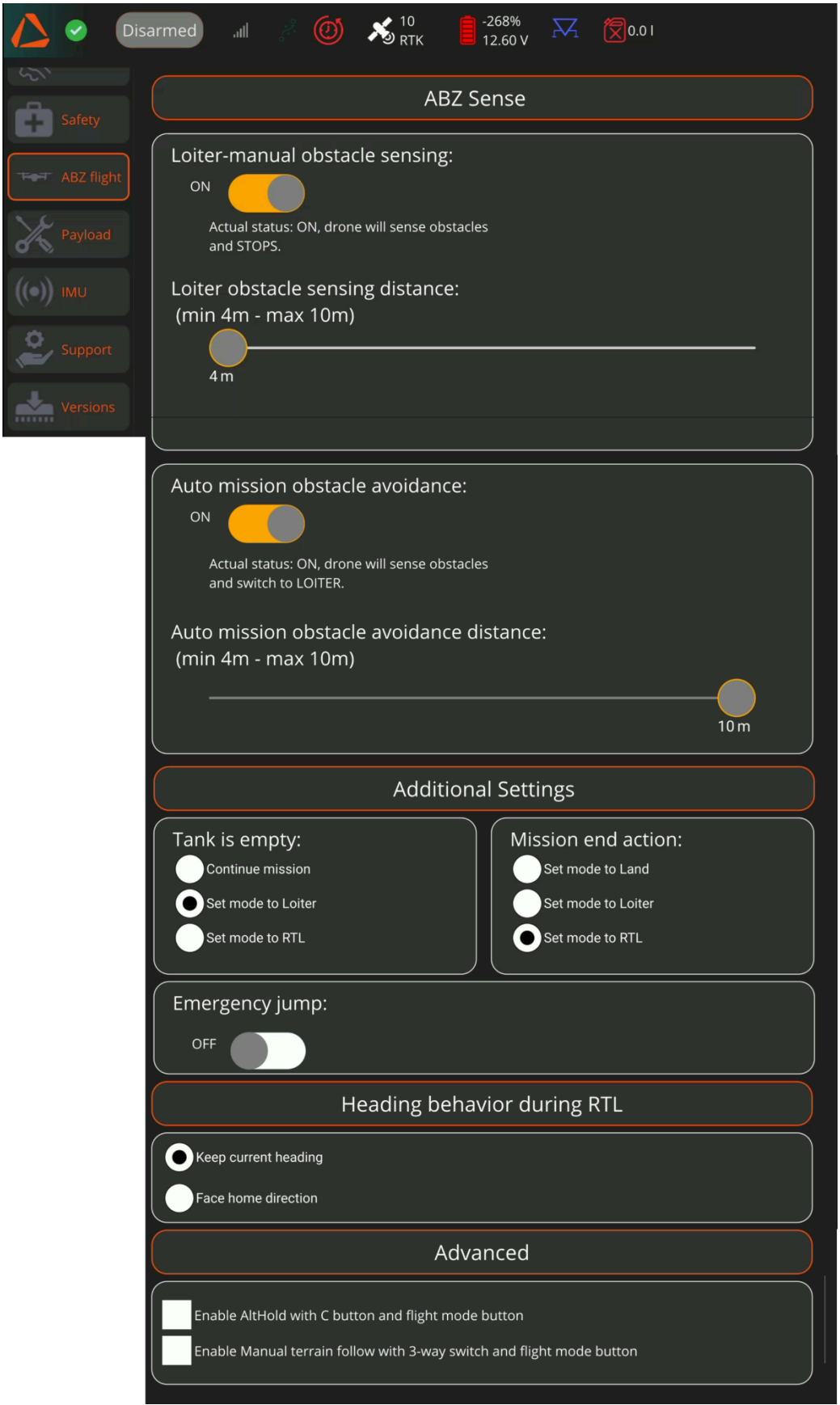

IMU - Compass calibration

Under the IMU option, the **Compass Calibration** can be carried out. **The calibration should only be performed if requested by the software or instructed by the Support Center.**

For further instructions, see [Compass Calibration](#) (page 109).

Software versions and Update

You can check the current **drone firmware** and **ABZ Control software** versions under **Settings > Versions**. If you contact our Support Center with an inquiry regarding your drone, you will be required to provide this information.



ABZ Innovation communicates all new software releases via email. Only perform updates when instructed to do so by ABZ Innovation.

ABZ Sense (only for drones equipped with LiDAR)

Obstacle Avoidance with ABZ sense (only for drones equipped with LiDAR)

The ABZ Innovation M12 drone uses the Multi beam LiDAR based ABZ Sense system to provide reliable obstacle avoidance, ensuring safe and efficient drone operations.

The Obstacle Avoidance (OBA) function is available in both manual (Loiter) and automatic flight modes. By default, it is enabled in manual mode and disabled in automatic mode. The obstacle avoidance is NOT FUNCTIONING when flying home with the „Return to Launch - RTL” function.



You can enable or disable Obstacle Avoidance via **Settings > ABZ Flight**.

When flying with obstacle avoidance enabled, the drone constantly analyzes its environment using its multi-beam LiDAR system. If an obstacle is detected, the drone stops at the distance defined as the obstacle avoidance distance.

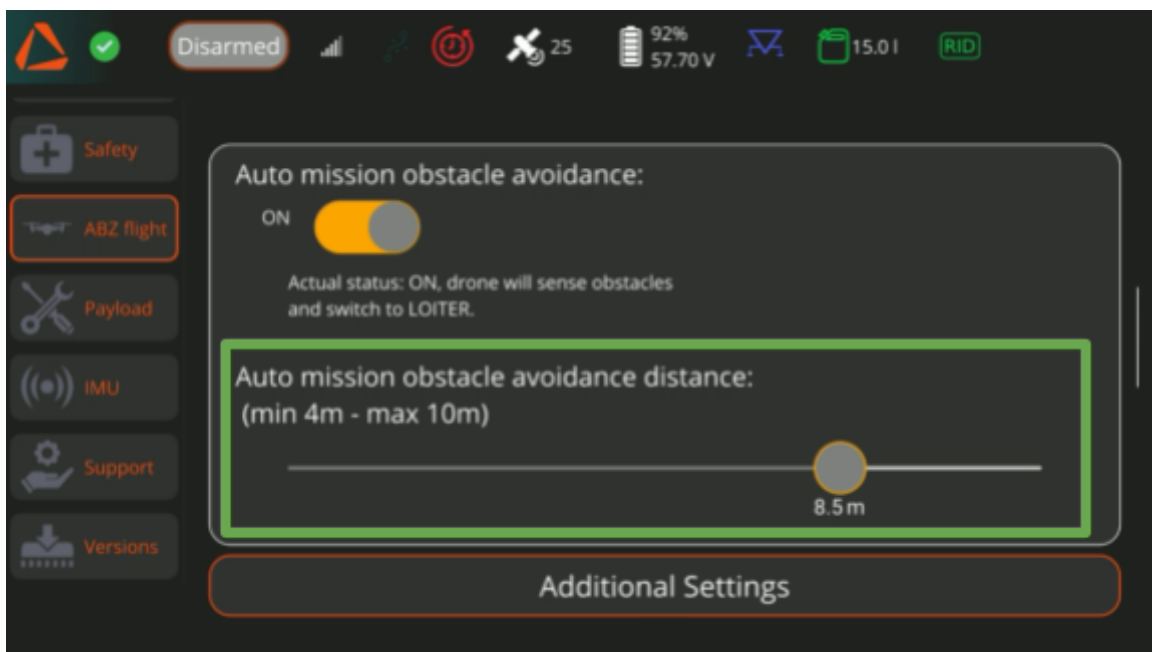
The obstacle avoidance distance can be set between 4 m (13.1 ft) and 10 m (32.8 ft), and can be considered outside of the drone's braking distance (you do not need to consider the braking distance when defining it). The drone consistently preserves the set distance from obstacles, actively pulling back when necessary.



The OBA icon in the top bar of the Flight View provides continuous feedback on the current status of the system when the drone is armed:

-  If the OBA icon is red, the obstacle avoidance is disabled.
-  If the OBA is green, the obstacle avoidance is operating. A small “M” or “A” on the icon indicates whether the system is operating in manual or automatic flight mode.
- 

If flying with obstacle avoidance enabled, you will see a blue arc moving at a fixed distance in front of the drone, indicating the scanning range. If the distance between the drone and the arc decreases, an obstacle has been detected.



Never rely exclusively on the obstacle avoidance system.

Always pay attention and observe the drone and its surroundings closely during flight.

Using obstacle avoidance, which is an additional safety feature, does not eliminate the need for pre-mapping obstacles, as executing missions with pre-mapped obstacles is always more time-efficient and precise.

What to do if the drone stopped because of an obstacle?

1. If flying an automated mission with OBA enabled, the drone will switch to Manual (Loiter) mode after detecting an obstacle and stopping at the defined distance.
2. If the drone has stopped, manually navigate it parallel to the obstacle until you reach the end of it.
3. Define a return point on the mission's route by clicking on the map. Tap the X button to modify the position of the return point.
4. Tap the checkmark to continue with the mission.
5. In the pop-up window, reconfirm the mission settings. The drone will fly to the designated return point and continue the mission from there.



You can also manually declare an obstacle during a mission by hitting the OBA Button in the Operation window.



Altitude control

Based on the characteristics of the working area and the requirements of the mission, you can choose between three altitude control methods.

- Follow terrain (LiDAR based - only for drones equipped with LiDAR)
- Relative
 - Barometer based
 - GPS based

The Follow Terrain altitude hold method relies on the ABZ Sense system. The multi-beam LiDAR continuously scans the environment and, based on a temporary real-time map generated from the point cloud, continuously and precisely adjusts the drone's altitude. This method is ideal for challenging terrains with significant height differences.

If flying in Relative Altitude Hold mode, the drone's altitude is maintained relative to the takeoff point.

In **Return to Launch (RTL)** mode and during automatic return-to-mission procedures, the drone uses the **Relative Altitude Hold** method to control altitude.

By default, Relative Altitude Hold mode uses barometric measurements as the primary height source. The pilot must be aware of altitude variations caused by atmospheric and weather changes. This mode is best suited for uniform and flat terrains.

If you are flying with an **Emlid base station or Network RTK source using correction data**, the drone relies on GPS information as Primary Height source. This is the optimal setting in conditions where the LiDAR's normal operation is limited—such as when flying over water bodies, glass surfaces, or other reflective materials. You can enable this mode in **Settings > ABZ Flight** when the drone is grounded and disarmed.

You can change the default primary Height source used by the drone under Settings > ABZ Flight.

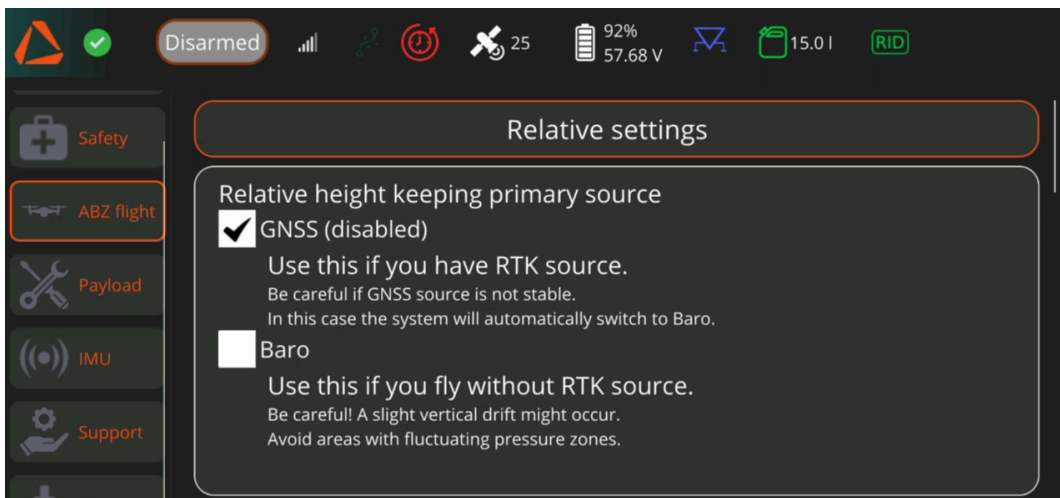

By default, in Manual Flight mode, the drone operates in Relative Mode. You can enable Manual Terrain Follow mode under **Settings > ABZ Flight > Advanced**. If enabled, you can toggle in manual mode between Follow Terrain (LiDAR-based altitude - only for drones equipped with LiDAR) and Relative Mode (barometer- or GNSS-based altitude hold) using the central three-stage switch or the Flight Mode button in Flight View.

To enable this feature, go to **Settings > ABZ Flight > Advanced**, and activate **Manual terrain follow with 3-way switch and flight mode button**.

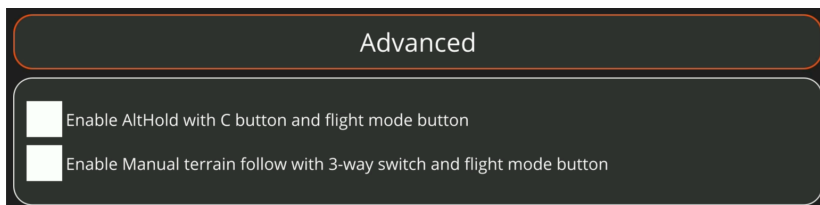

In automatic flight mode, you can predefine the altitude hold method for the mission in the Mission settings.



If Relative Altitude is selected, the drone relies on either barometer data or GNSS for altitude control, depending on the settings in **ABZ Flight**. Use GNSS only when flying with RTK correction. If GNSS data becomes unreliable, the drone will switch back to barometric altitude hold.

Always define the mission altitude measured from the highest point of the plants you will be flying over.

In Return to Launch (RTL) flight mode and during Return to mission, the drone will use the relative altitude hold method.

Flight planning

To access the drone's Flight Planning features, click the white **A-B** icon in the top-right corner. This opens the **Mission Planning Method** page, where you can choose from the following options:



- **Manual** (Marking the area with the drone/with the Remote controller)
- **SHP/Area drawing** to upload Area based SHP files (polygon or multipolygon) or draw the Mission Area onto Maps
- **Load Mission** (Loading a previously saved mission).
- **Advanced planning** (waypoint based flight route planning).



For safety reasons, if your location or flight plan has changed, make sure to clear the previous mission from the drone by:

- clicking the **Exit button** in the Operation window under the Flight view,

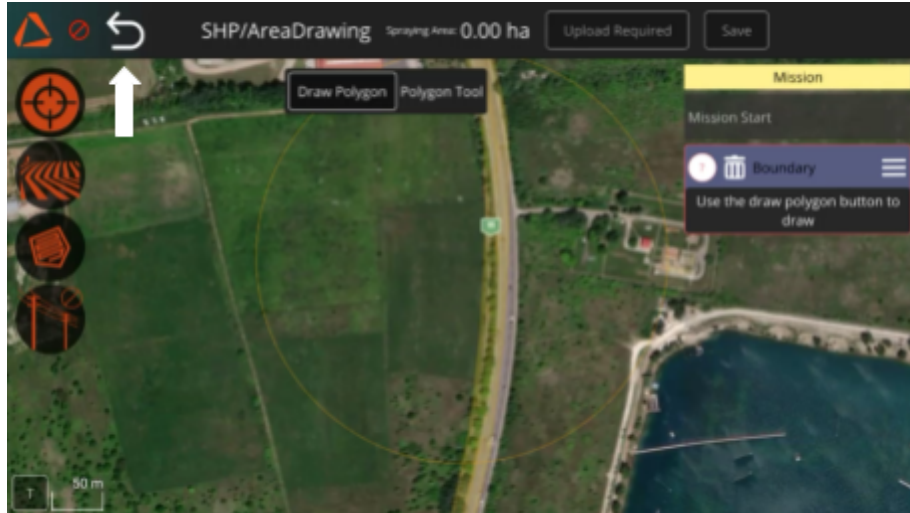

- Or by clicking the **Back button** on the Flight Planning page.



Waypoint based Flight Planning

Advanced Planning

The **Advanced Planning** is a mission planning interface designed for creating complex tasks—such as differential applications or spot treatments—by providing full control over the drone’s flight paths. Unlike Manual Planning or Area Drawing, where boundaries must be set, this feature gives you complete control over the drone's flight routes.





Within a single waypoint mission, you can assign different flight parameters (e.g. speed, altitude, and spacing) and specific servo commands to individual waypoints. These capabilities allow the drone to execute operations with a high degree of precision and flexibility.

To enter the **Advanced Planning**, navigate to the Mission Planning Method Page and select Advanced Planning.

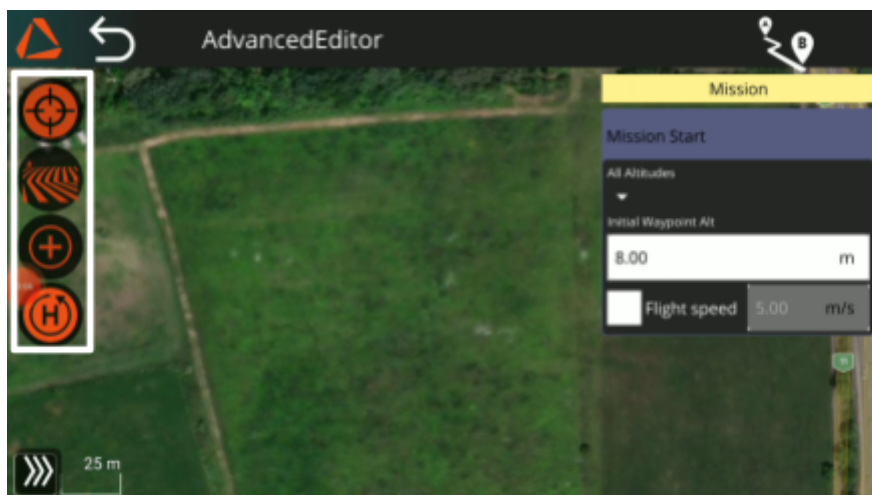

On the left side of the planning page, you will find four buttons:



-  **Center:** places the mission, the drone's position, or the remote controller's position in the center of the screen with a single click.
-  **SHP:** you can add visual guides to the map to help you with the accurate placement of the waypoints. It offers several options: Point, Polyline (Lineshape file), or Polygon. For further information regarding [Using Shapefiles as Visual guides](#), see page 84. You can also open a [Polyline shape File to configure it as a Waypoint mission](#) (for instructions, see page 88).
-  **Waypoint:** You can set specific waypoints by tapping on the remote controller's screen to create the drone's route.
-  **Return:** activates the return-to-home function once the drone has completed the last waypoint. It is considered as part of the mission.

On the right side of the planning page, in the mission panel, you can set the Mission start parameters and the parameters of the waypoints.

The parameters you define in the mission start section will be inherited by all the waypoints.

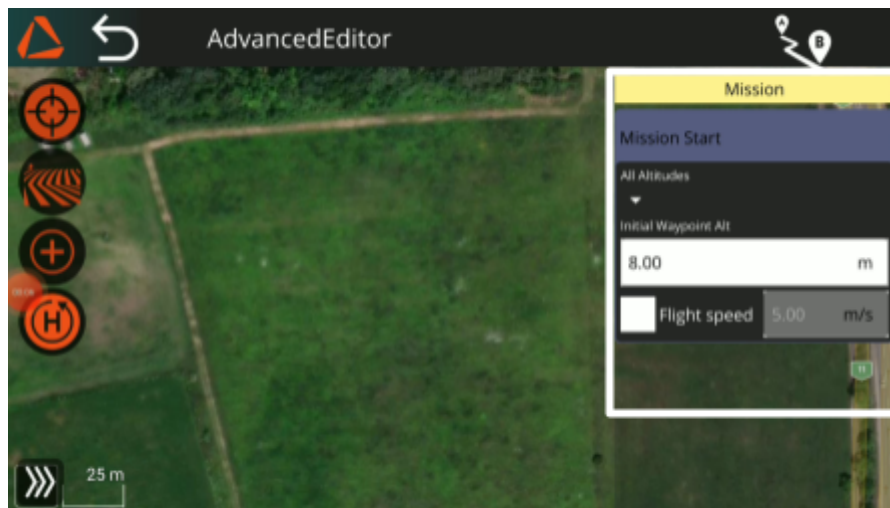

During the planning process, if you change the setting for any waypoint, the subsequent waypoints will inherit the new setting.

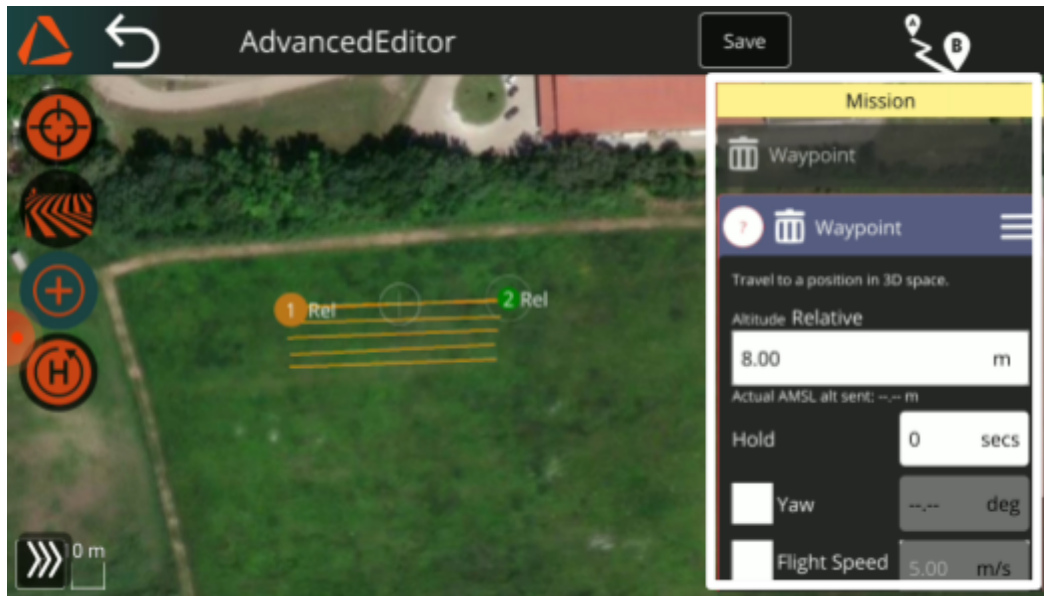

Waypoint mission planning process

1. In the **Mission Start** section of the right-hand **Mission Panel**, define the **Flight Speed** and the **Altitude Hold Mode** for your mission. Make sure to check the box next to the **Flight Speed** value; otherwise, the speed will not be applied.

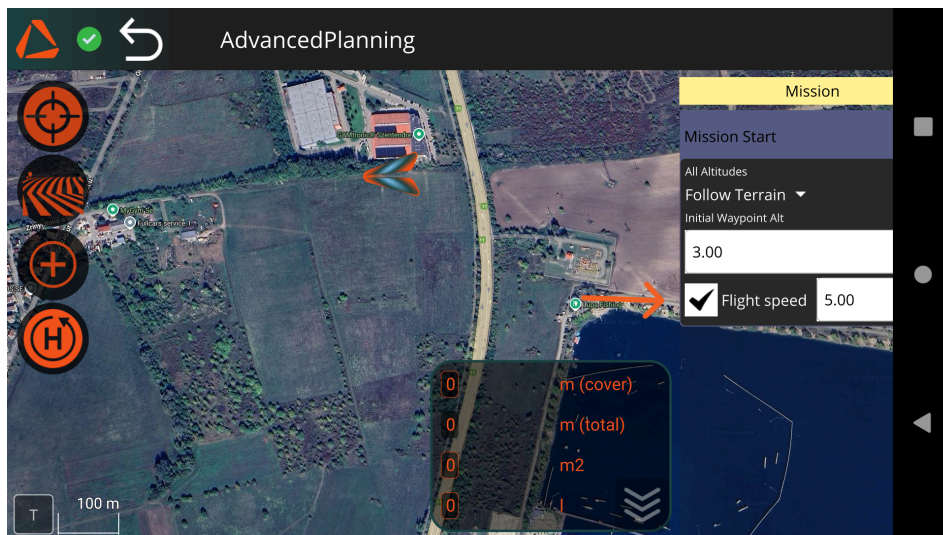

For **Altitude Hold Mode**, you have three available options. (For further information regarding [altitude Control methods](#), see page 53):

- **Relative:** The drone's altitude will be relative to the takeoff point
- **Follow Terrain:** The drone uses LiDAR to maintain altitude, measured as its distance from the ground. (only for drones equipped with LiDAR)
- **Mix Modes:** Allows applying the previous two modes individually for each waypoint.

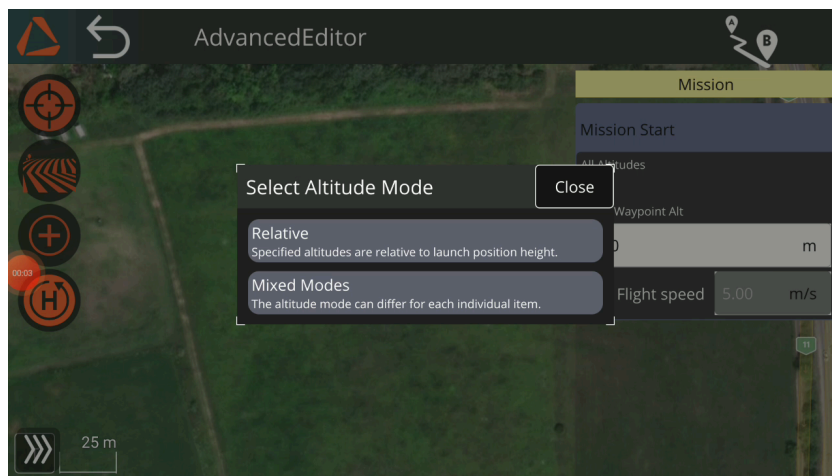

2. Add the waypoints by tapping on the screen. You can grab and move the points to reposition them.



3. To avoid inaccuracies in planning caused by the inevitable limitations of online maps, use shapefiles to ensure the precise placement of the waypoints. For [further instructions](#), see page 84.

4. You can delete a waypoint by clicking on the bin icon in the Mission Panel.



5. In the mission panel, you can adjust the flying parameters, including altitude and speed, individually for each waypoint. The subsequent waypoints will inherit the setting.



6. Click the arrow next to **Set Servos** to set-up the payloads connected to, and associated with, the servos at the given waypoint.

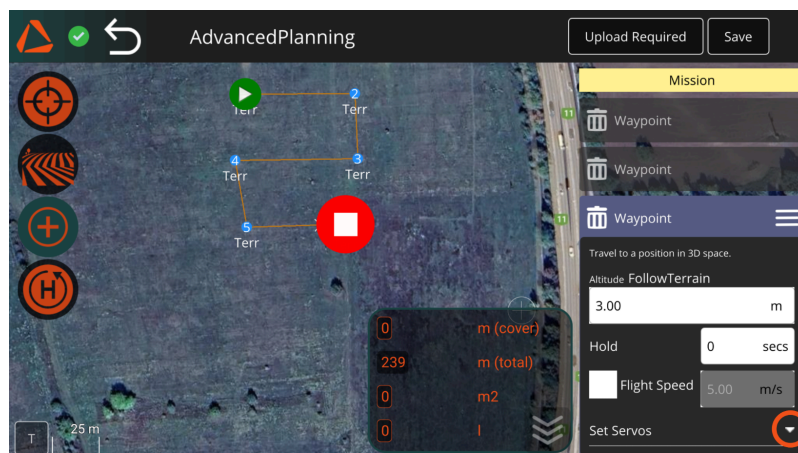

- To activate a servo at a waypoint, select the box next to it and set the PWM value you want to use to control the payload.

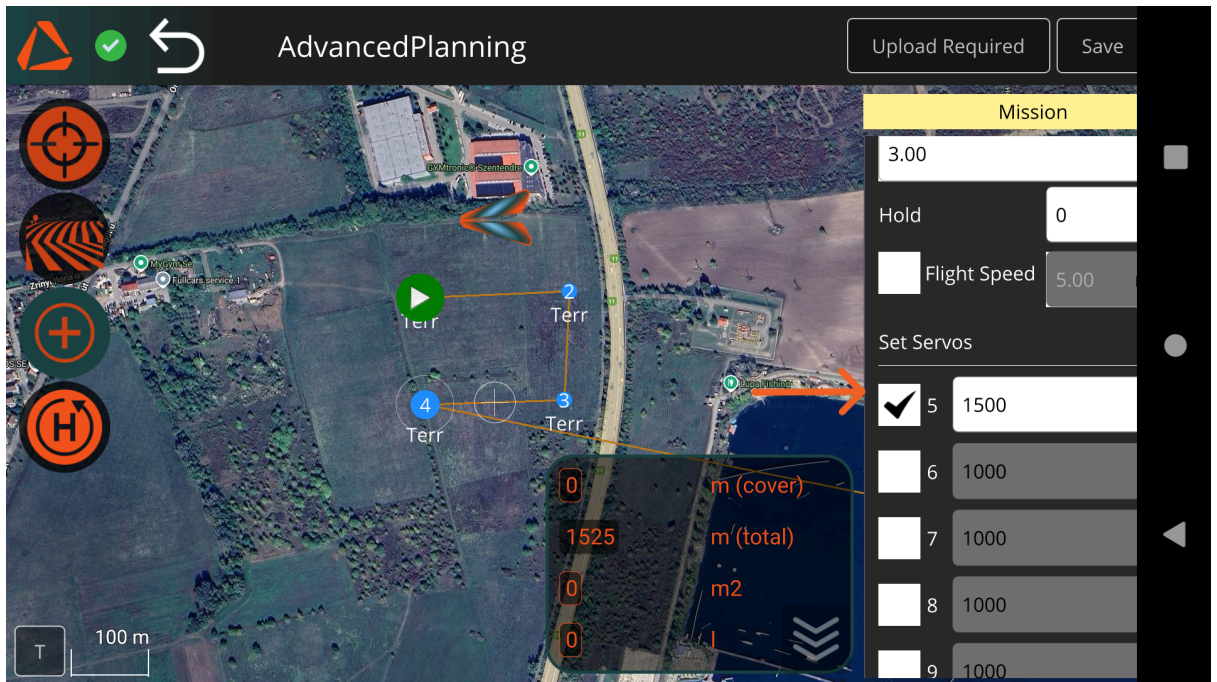

- Using the Return button (on the left side), you can instruct the drone to initiate Return to Launch (RTL) at the end of the mission. Otherwise, after reaching the last waypoint, the drone will follow the Mission End Action setting, which can be defined under **Settings > Safety**.



9. In the Statistics Window, after entering the mission parameters, you will see the calculated details of your Mission:
 - a. Route with spraying activated (only relevant for L-series drone's)
 - b. Entire flight route
 - c. Area to be sprayed (only relevant for L-series drone's)
 - d. Required spraying liquid (only relevant for L-series drone's)

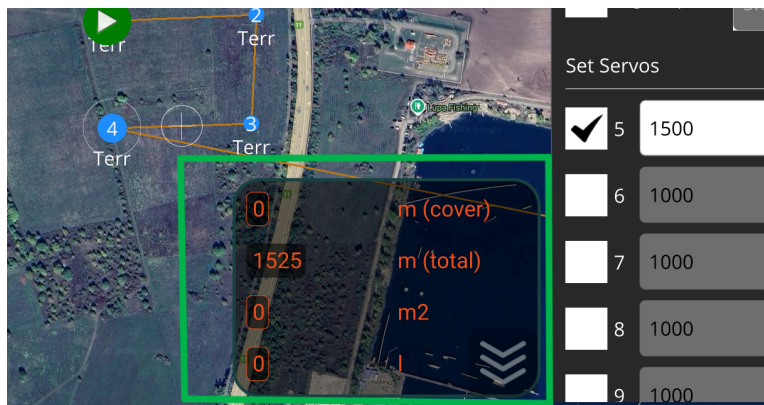

10. When you have finished editing, you can save the mission by clicking the **Save** button on the right side of the top menu bar. To upload the planned route to the drone, click the **Upload Required** or **Upload** button at the top-right corner of the screen.
11. To start the mission, navigate to the **Flight view** by clicking on the ABZ Innovation logo. In the Operation window, tap on the **'Start Mission'** button after manually flying the drone to a safe altitude. For further information regarding [starting a mission](#), see page 72.
12. If you leave the planning page by clicking on the back button, your plan will be cleared from the editor and from the drone. If you have saved your plan, the file remains on the controller and you can open it from the Load mission menu.

Area based flight planning

You have three options for creating a mission plan for a predefined area:

- **Manual** (Marking the area with the drone/with the Remote controller)
- **SHP/Area drawing** to upload Area based SHP files (polygon or multipolygon) or draw the Mission Area onto Maps
- **Load Mission** (Loading a previously saved mission).

When using are based planning, each flight plan can include one Boundary (the working area where the drone will execute the automatic mission), and optionally one or more Obstacles (areas the drone will avoid during the mission).

At least three points are required to define a boundary or an obstacle.

Planning the field with the drone/ with the remote controller

You can use **the drone's camera/the remote controller** to mark the points of an area to specify a Boundary or Obstacle. To do so, on the Mission Planning Method Page choose the option **Manual**.

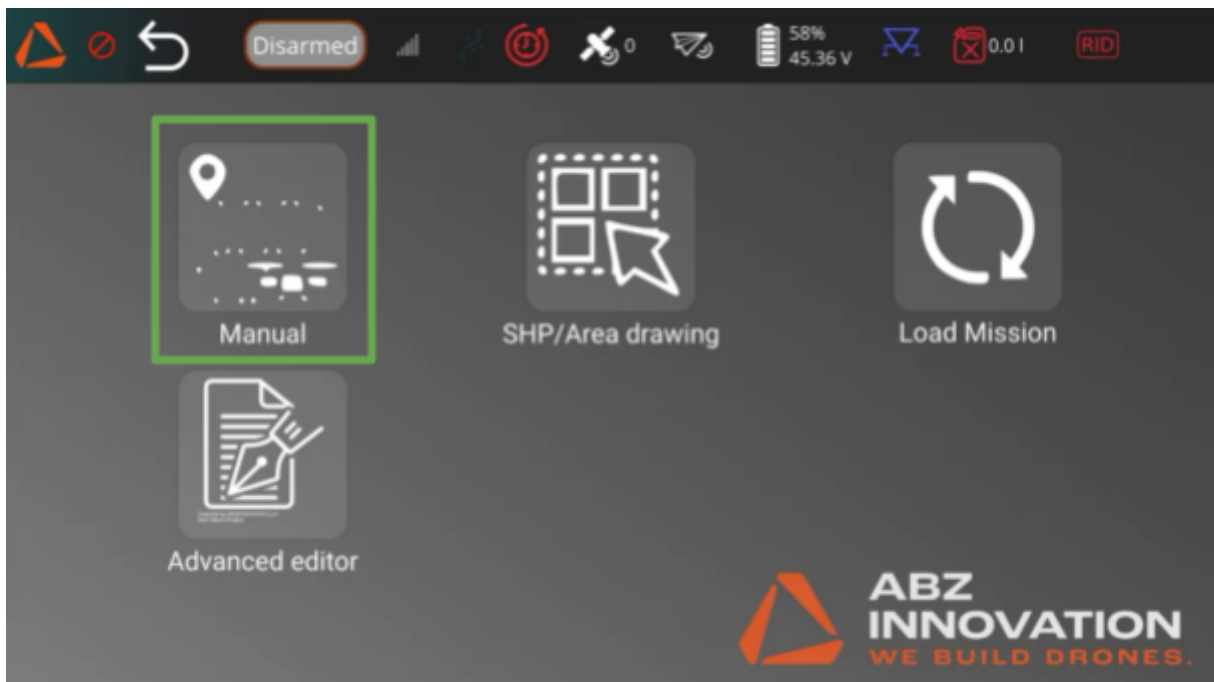

With the Center option, you can decide what should be in the central position on the map (the mission, the Drone, or the Remote Controller).

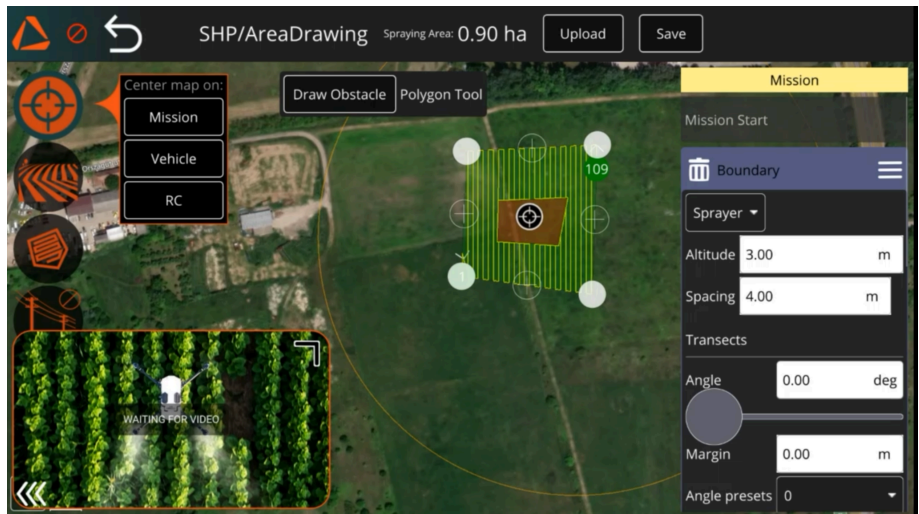

1. To define your working area for a new flight plan, Click on the Boundary icon.



A flight plan can only have one boundary. If you want to create a new one, the old one needs to be cleared.

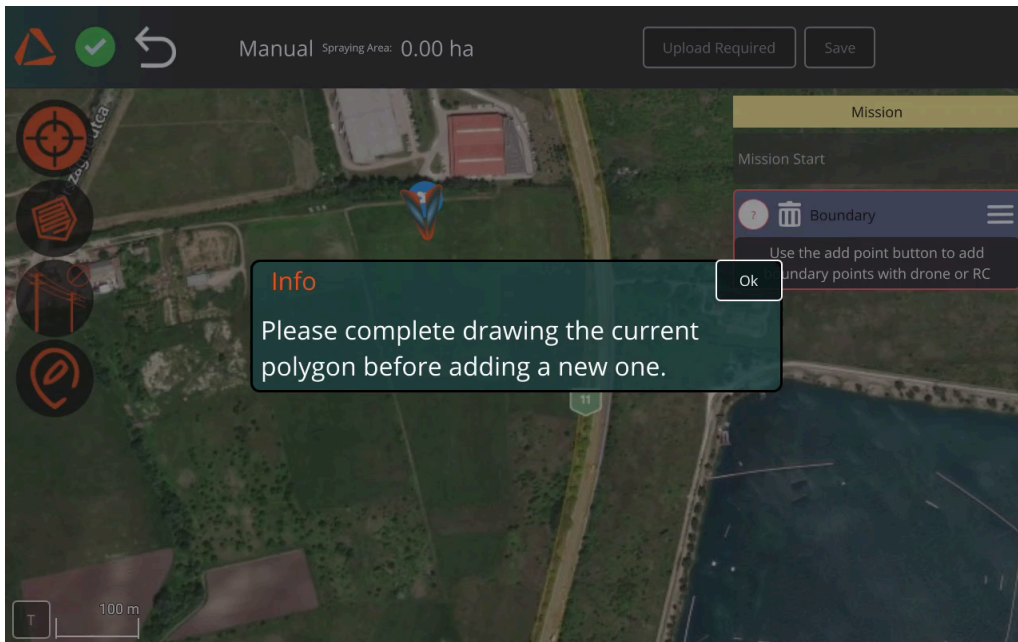

2. After defining the Boundary, you can add points to it. To do so, the Boundary element needs to be active on the right side panel.
3. Click on **Add Point** in the left side menu. The points can be marked by the Remote Controller (RC Point) or the Drone (Drone Point).



To plan a mission using the drone, fly it to the desired points with the help of the camera and allow it to hover at each location. Then click on the **Drone Point** button on the left of the display to add the desired points.

Points can also be manually moved on the display, based on the map, by tapping and dragging.

In this case, you should be aware of the inaccuracy of the background map, which can be several meters off!

If you want to plan with the Remote Controller, take the controller to the desired point. Then click on the **RC Point** button on the left of the display to add the desired point.

If you have defined at least 3 corner points for the boundary, the Mission panel will open up on the right side for [additional settings](#) (see page 70).

4. To mark an Obstacle, first click on the Obstacle button.
5. Select the obstacle in the Mission panel and define its points by either the position of the Drone or the Remote Controller. You can define multiple obstacles; the points will be added to the obstacle currently selected in the Mission panel.





Using obstacle avoidance, which is an additional safety feature, does not eliminate the need for pre-mapping obstacles, as executing missions with pre-mapped obstacles is always more time-efficient and precise.

Never rely exclusively on the obstacle avoidance system.

Always pay attention and observe the drone and its surroundings closely during flight. If possible, manually fly the drone as close as possible to the desired starting/continuation point!

Adjusting the mission settings

After defining a boundary, you can define the automatic mission settings in The Mission panel on the right side of the screen.

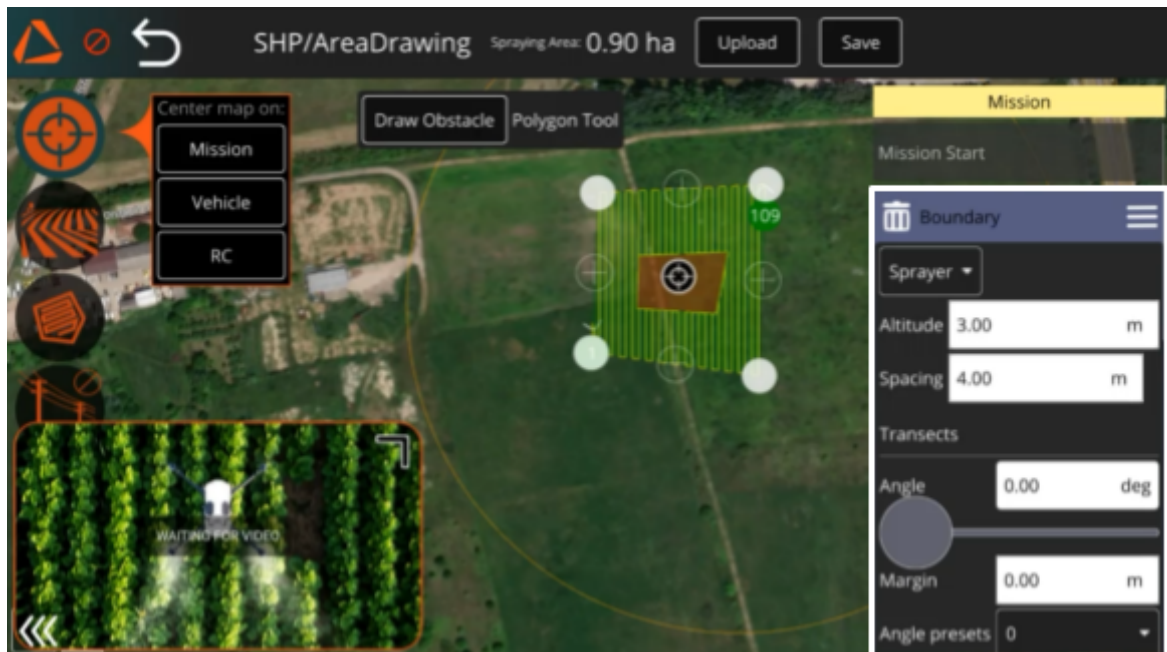

In this panel, you can adjust the following settings:

- Payload Type (Relevant only for L-series drones)
- **Flight altitude**
- **Line spacing:** the distance between the drone's flight paths
- **Angle** of flight direction (also adjustable with the slider)
- **Margin** (distance kept from the edge of the designated area)
- **Angle presets** (to match the flight direction with the area's edges)
- Rotating the position of the **first waypoint** (it is recommended to set it the closest distance to the take-off point)
- **Altitude hold method**
- Droplet size (only relevant for L-series drone's)
- Optional: Change droplet size scale to ISO Category. (only relevant for L-series drone's)

- Coverage (only relevant for L-series drone's)
- Flight speed (ground speed, also Adjustable with the slider: m/s or mi/h)
- Statistics (calculated data according to the settings, at the bottom)

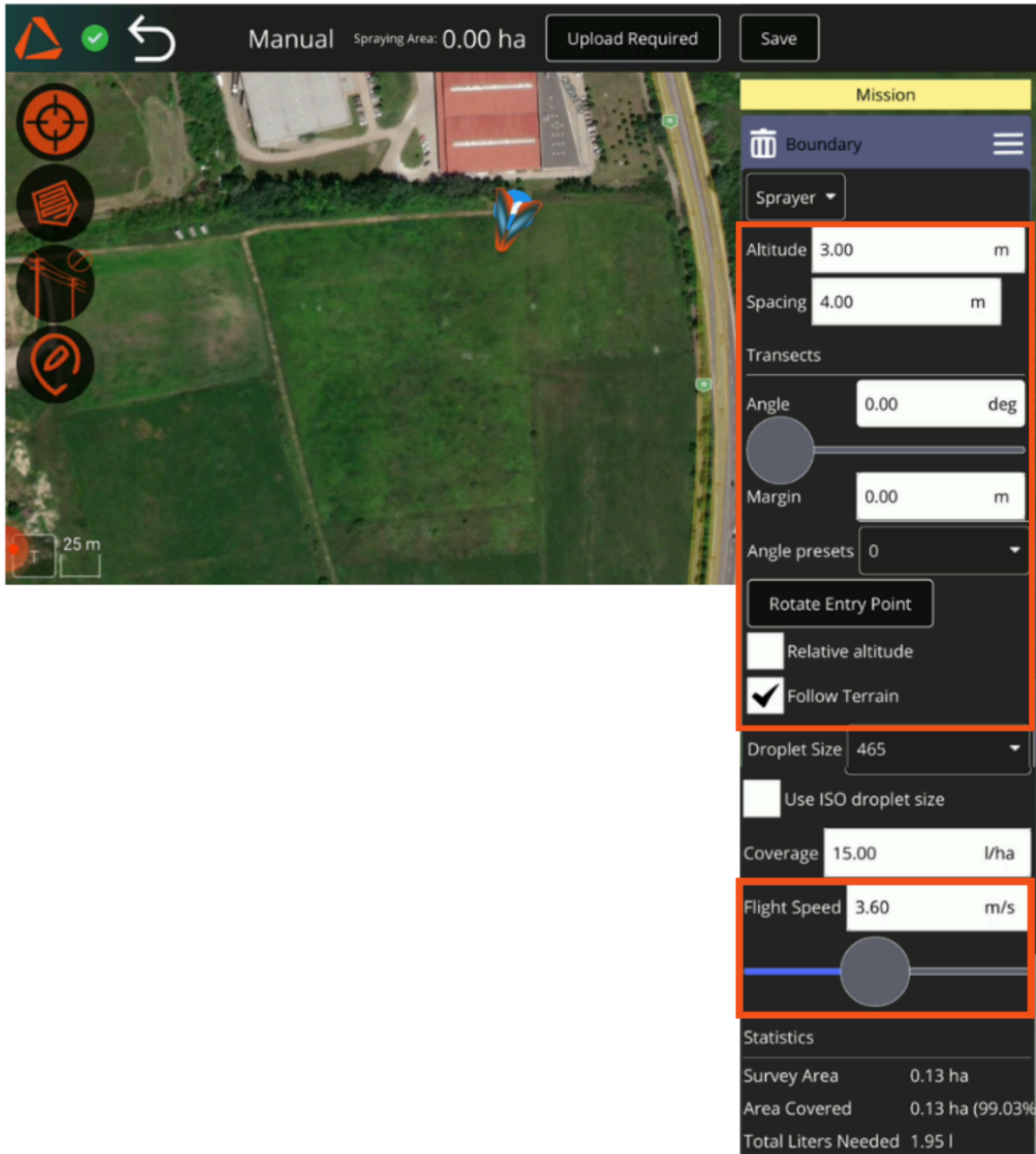

Flight Planning

ABZ Innovation M12

To upload the planned route to the drone, click the **Upload Required** or **Upload** button at the top-right corner of the screen.



If you save your plan, the file remains on the controller and you can open it from the **Load mission** menu. If you click on the **Back** button, your **plan will be cleared from the editor and from the drone.**

Starting the mission

To start the mission, navigate to the **Flight View** by clicking on the **ABZ Innovation logo**. In the down-right corner of the screen, the **Operation window** displays the upcoming steps and provides access to essential functions throughout the mission.



- **With the Options button (1)**, you can change the Mission settings (height, speed and spacing) after pausing the mission.
- **With the OBA button (2)**, you can manually declare an obstacle. (For more information on [obstacle avoidance](#), see page 50.)
- **With the Exit button (3)**, you can clear the mission from the drone.

Before starting the mission, the software will prompt you to enter a virtual tank status by indicating that the tank is empty (you can choose any number). You can enter the value by clicking the **Options** button.



After being prompted to arm and take off, manually fly the drone to a safe altitude before starting the mission. You can start the mission by tapping the Start button in the Operation window.

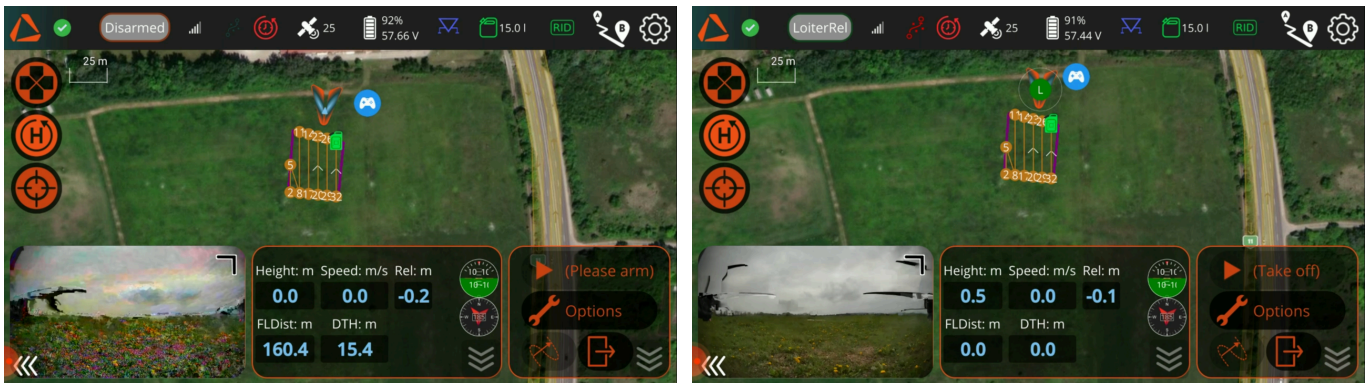

The system will then prompt you to confirm the mission settings. If all settings are correct, confirm by using the slider.



Planning the field by drawing an area

Under the SHP/Area drawing menu, you can manually add and move (by tapping and dragging) corner points on the display based on the map. In this case:

Be aware that the map may be inaccurate by several meters. To ensure precise placement of your boundary, we recommend using shapefiles as visual guides.

Important: Without shapefile-based visual guides, this solution is only intended for testing and demonstration purposes.

With the Center option, you can decide what should be in the central position on the map (the mission, the Drone, or the Remote Controller).

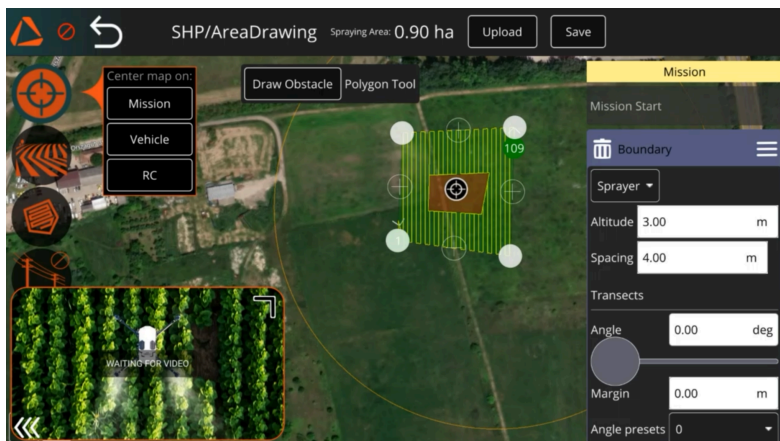

With the the **Shapefile** icon , you can add visual guides to the map to assist with accurate boundary placement.

(For more information on [using shapefiles as visual guides](#), see page 84.) To define a boundary by

drawing an area, click the **Boundary** button , then select **Draw Polygon**.

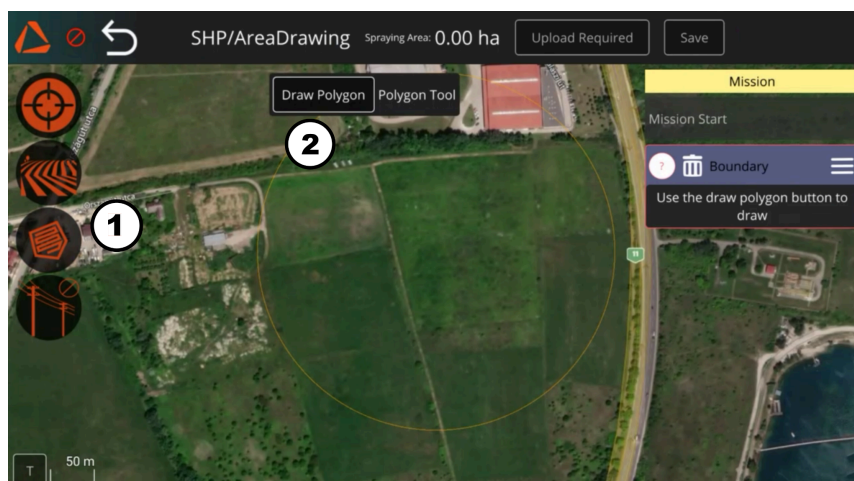

A polygon will be automatically generated, and you can adjust its corner points as needed.

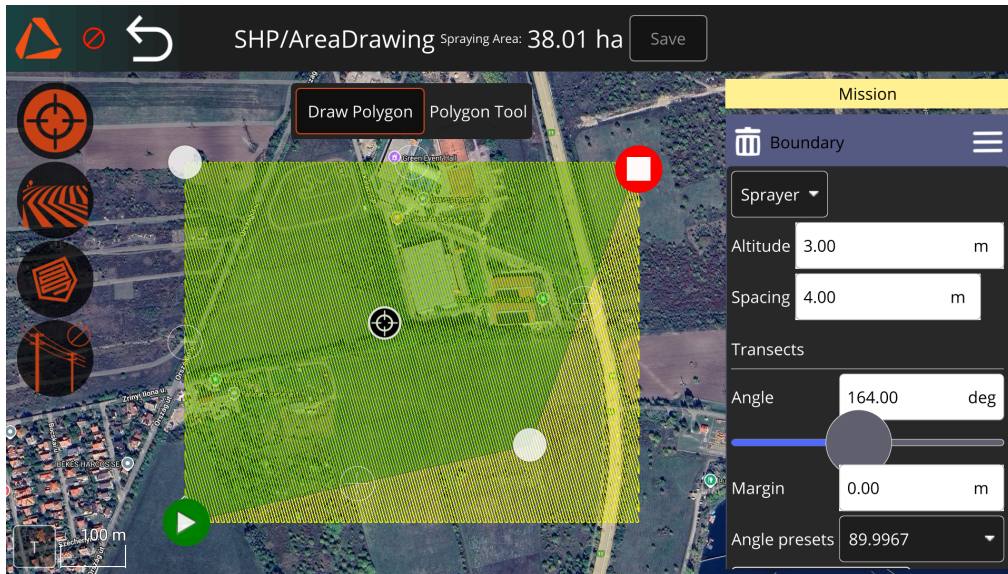

You can add an obstacle in the same way by clicking the obstacle icon and selecting **Draw obstacle**.

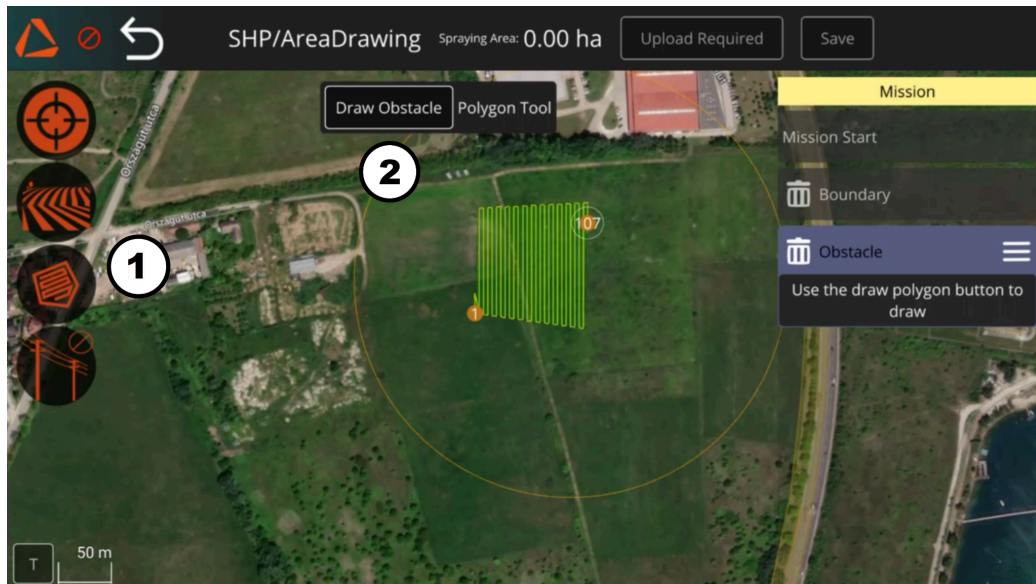

After you have adjusted the points, you can [specify the mission settings](#) for the mission (see page 70).

When you have finished editing, you can save the mission by clicking the **Save** button on the right side of the top menu bar. To upload the planned route to the drone, click the **Upload Required** or **Upload** button at the top-right corner of the screen.



To start the mission, navigate to the **Flight view** by clicking on the ABZ Innovation logo. If you leave the planning page by clicking on the back button, your plan will be cleared from the editor and from the drone. If you have saved your plan, the file remains on the controller and you can open it from the **Load mission** menu.

To start a mission, in the **Flight view** tap on the **'Start Mission'** button after manually flying the drone to a safe altitude. For more information on how to fly a mission, see [page 72](#).

Using shapefiles for mission planning

The ABZ Control supports polygon, polyline, and point-based shapefiles. You can use a shapefile in two distinct ways:

- To define an **area** (for further information regarding [polygon based missions](#), see page 86) or **flight paths** (for further information regarding [polyline based missions](#), see page 88)
- To serve as a [guide for precisely positioning](#) the points of a boundary or waypoints (for further information, see page 84.)

To import a shapefile into ABZ Control:

1. Make sure, **all** the needed shapefile parts are included in the .zip archive or shapefile folder (the files with extensions **.shp**, **.shx** and **.dbf** are present).
2. Ensure that the folder/archive has the **same filename** as the individual files.
3. Insert the SD card to the Remote Controller or copy the files to its internal storage with a cable:
 - If using an SD card:

A, insert the card into the SD card slot. Only MicroSD cards with a maximum of 32 GB capacity are supported. You can decide to import the files directly from the SD card or copy them to the Remote Controller:

B, To copy them, wipe down from the top of the screen to access the Android menu, where you must press the gear (**Settings**) icon.

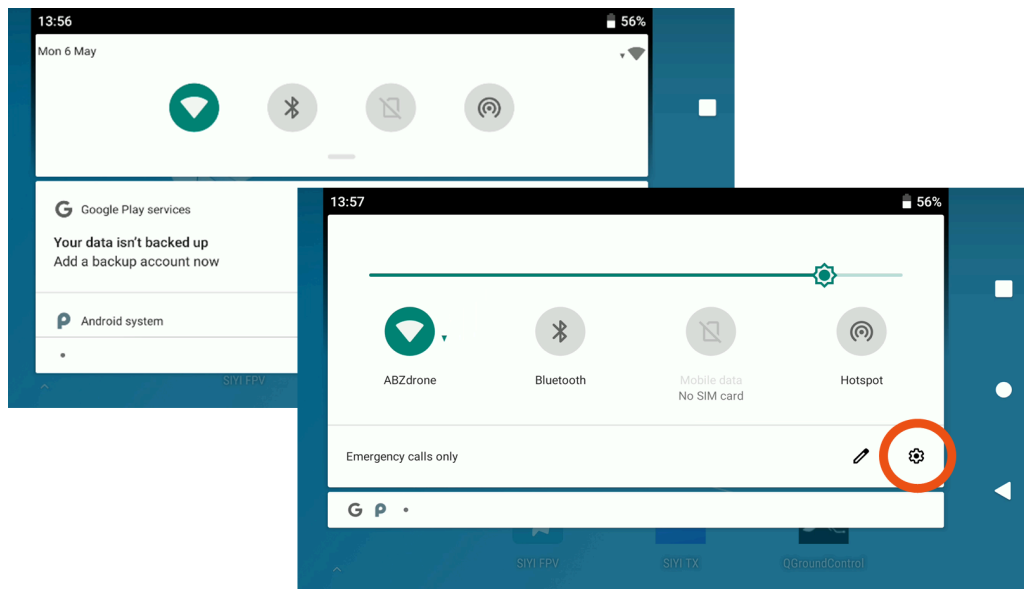

B, In this menu, scroll down to Storage, where you can select to open the SD Card.

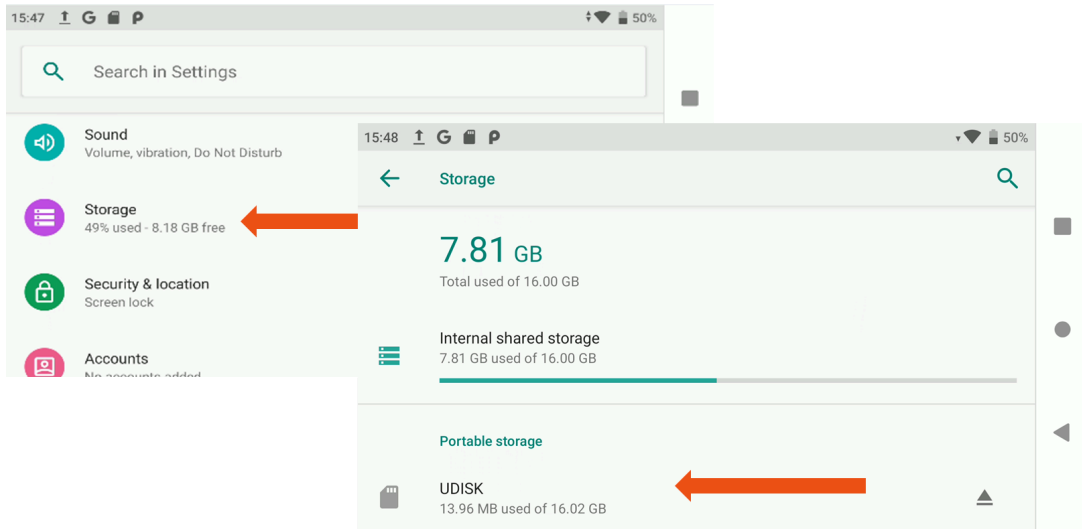

C, Tap the top right Others (3 vertical dots icon) menu, then **Show internal storage**.

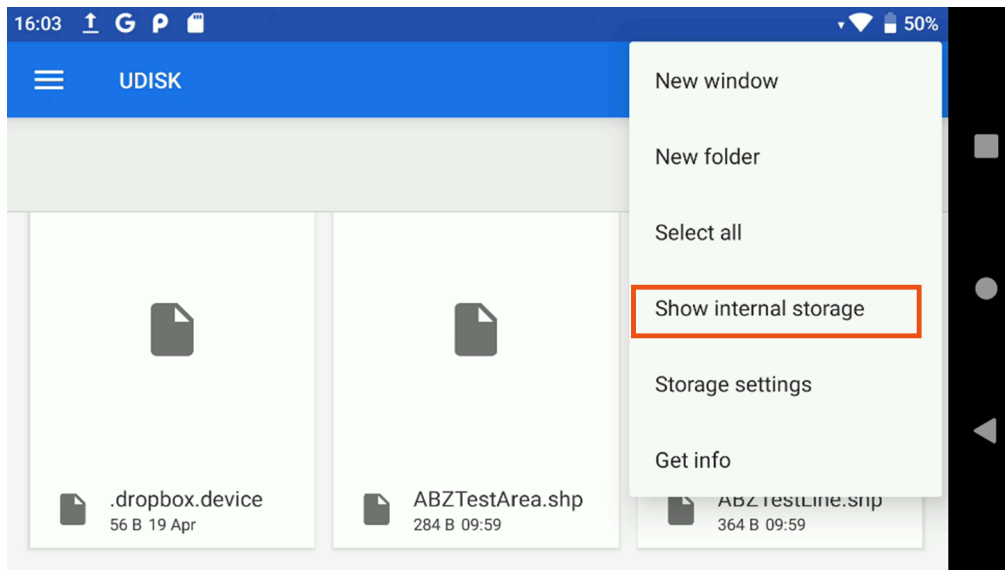

D, Select the required files on the SD card (tap and hold), then click on the Others (3 vertical dots icon) menu in the right corner of the screen, and select Move to...

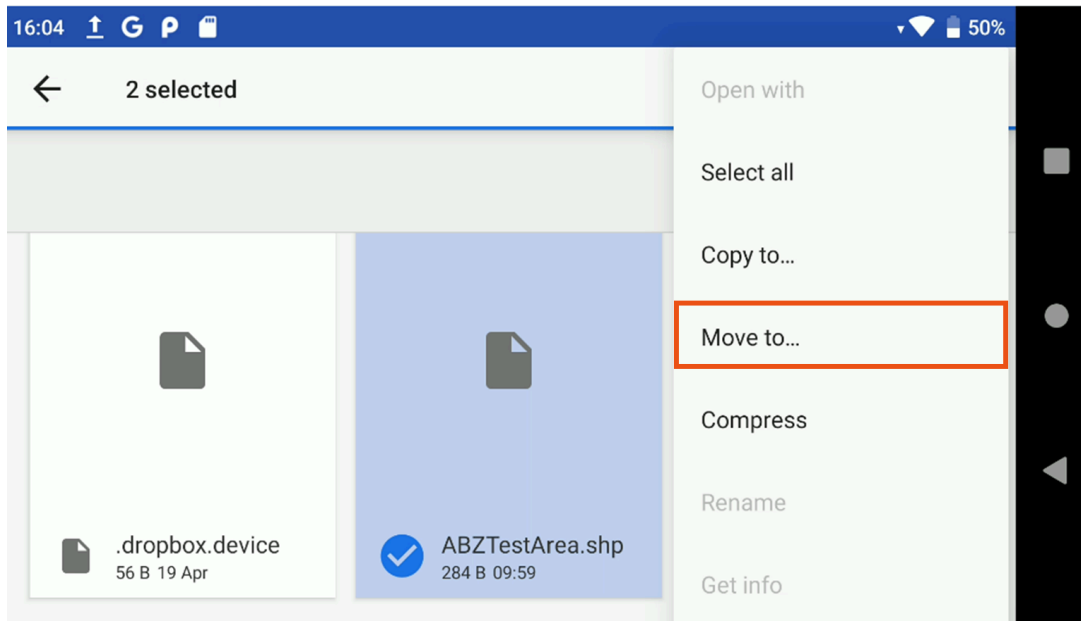

E, Click on the three lines on the left to open the navigation bar. Select MK15, then open the folder (e.g. Downloads) where you want to store your shapefiles. Click the bottom right Move button to move the files to the controller.

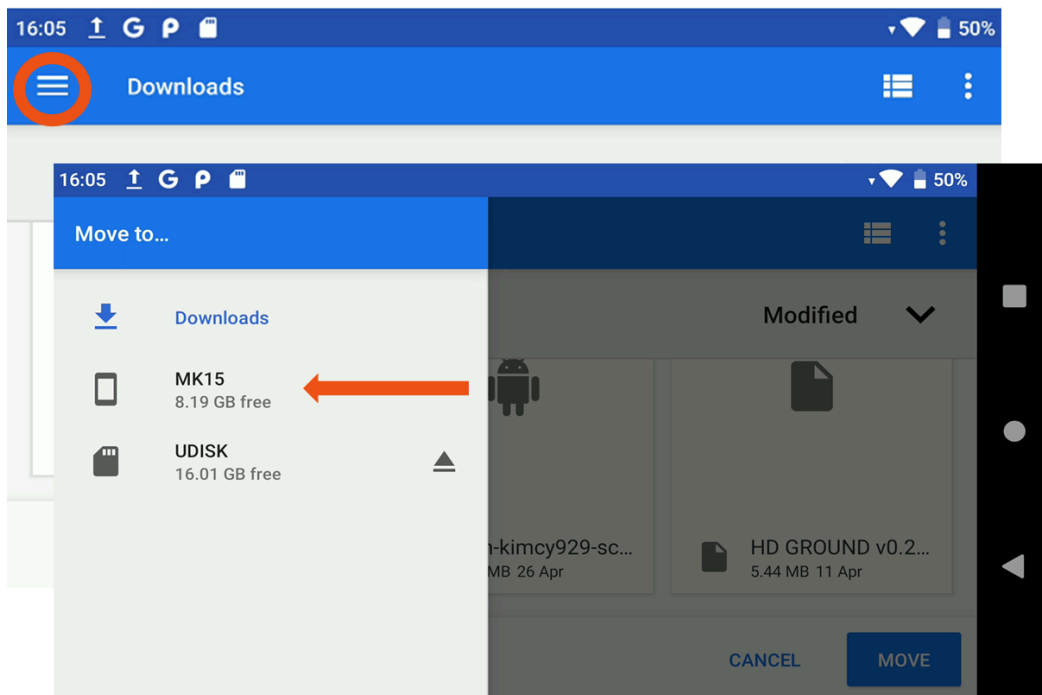

- If you use a cable, connect the cable to the USB-C port of the remote controller and the computer.

A, Open the Android Settings by swiping down from the top of the screen.

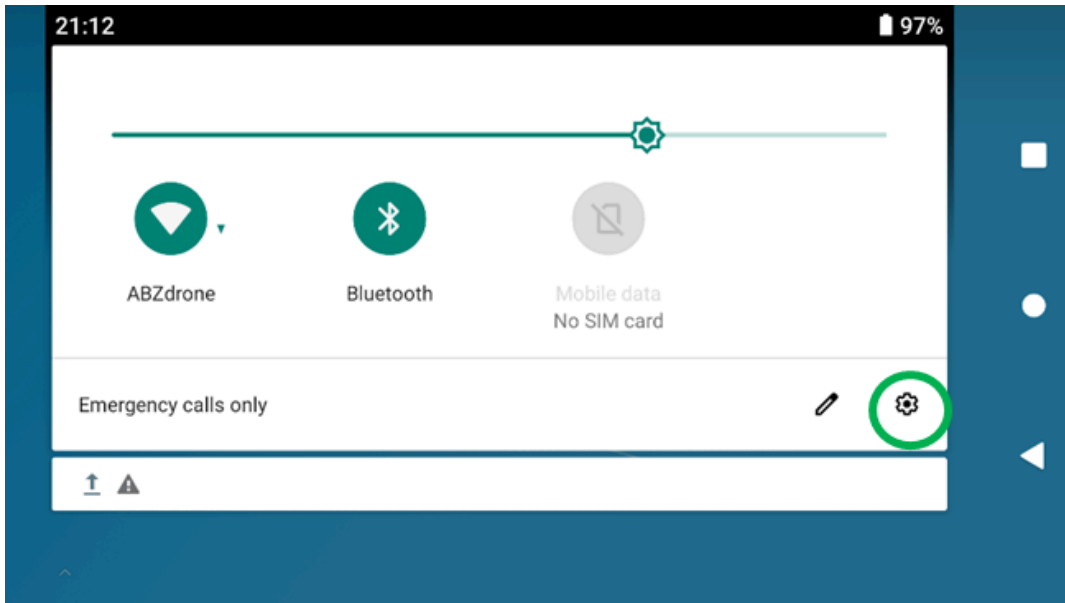

B, In the search bar, enter “USB”. Look for the option USB preferences. Click on File transfer.

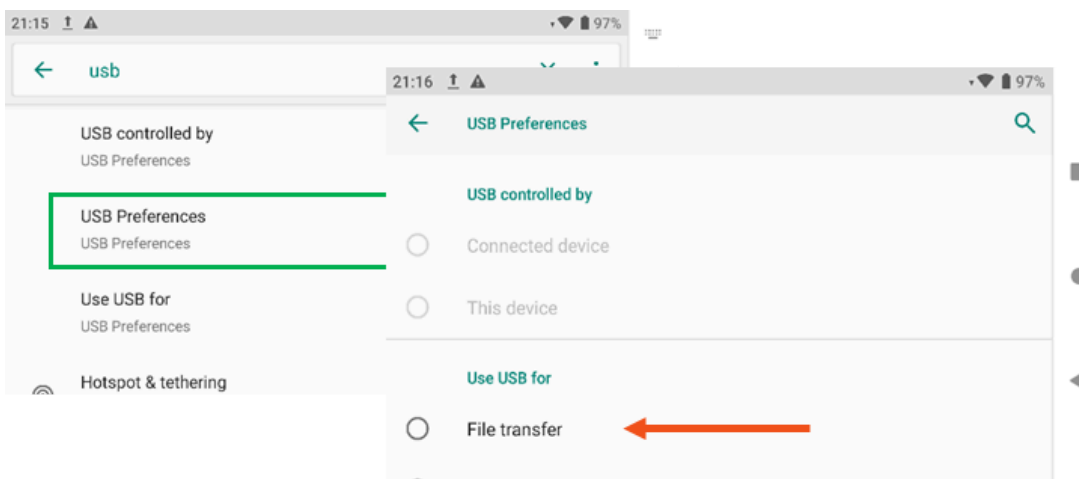

C, On your computer, the device MK15 appears. Copy the shapefile to the Controller.

D, You can disconnect the cable.

4. Launch the ABZ Control, and open the *Settings* > *SHP* Option.

5. Click **Import**.

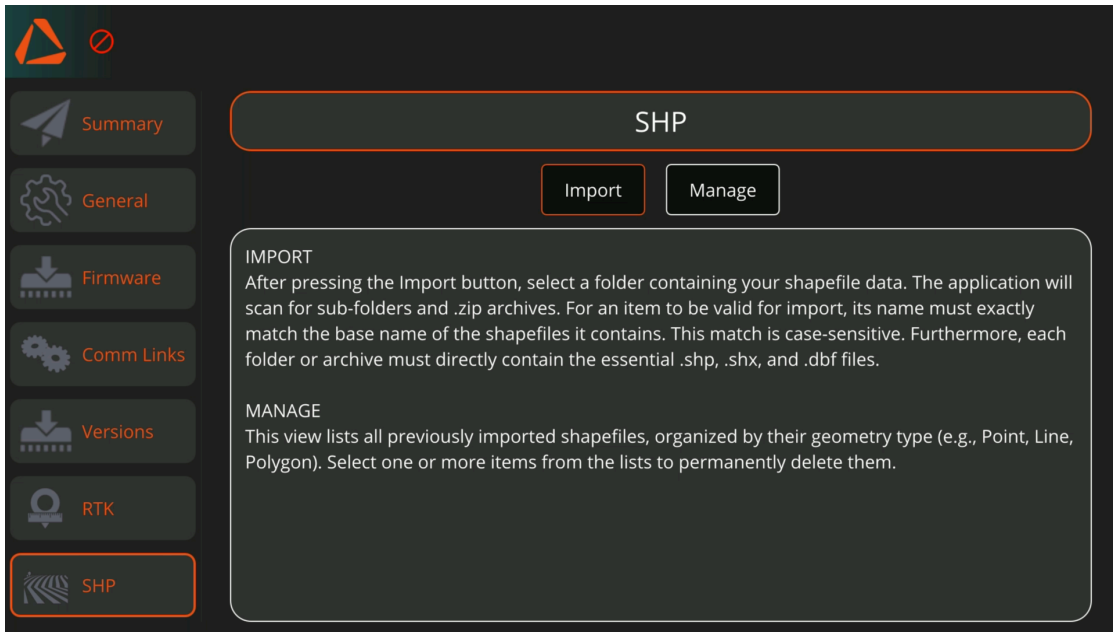

6. In the browser window, navigate to your shapefile folder/ZIP archive file.
(Do not open it!)

7. Click on **Select**.

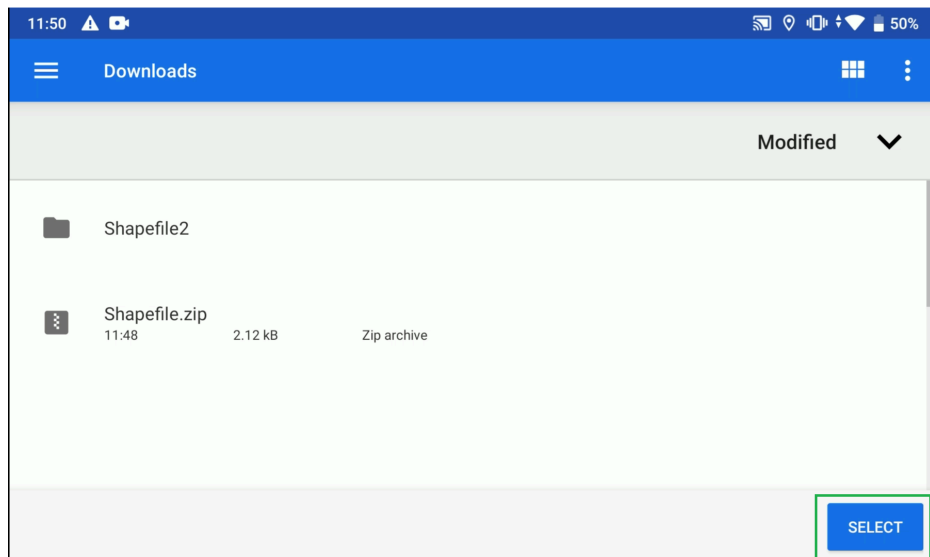

8. Mark the needed shapefiles with a checkmark, and click on **Import selected**.

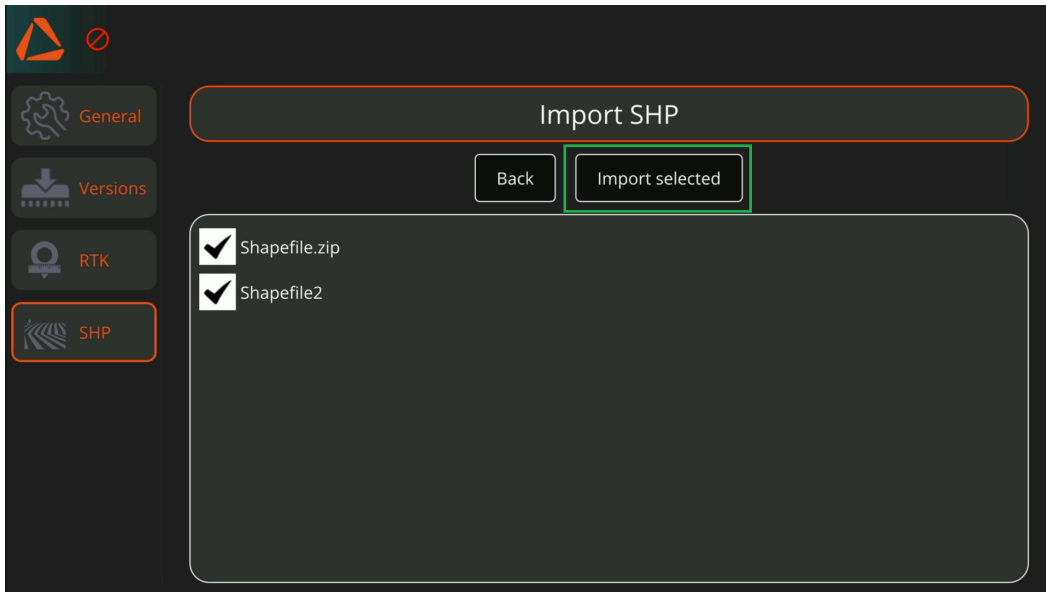

To Delete an imported shapefile, click on Manage. You will find the imported files grouped by their geometry. Select the files you wish to delete, and click on **Delete selected**.

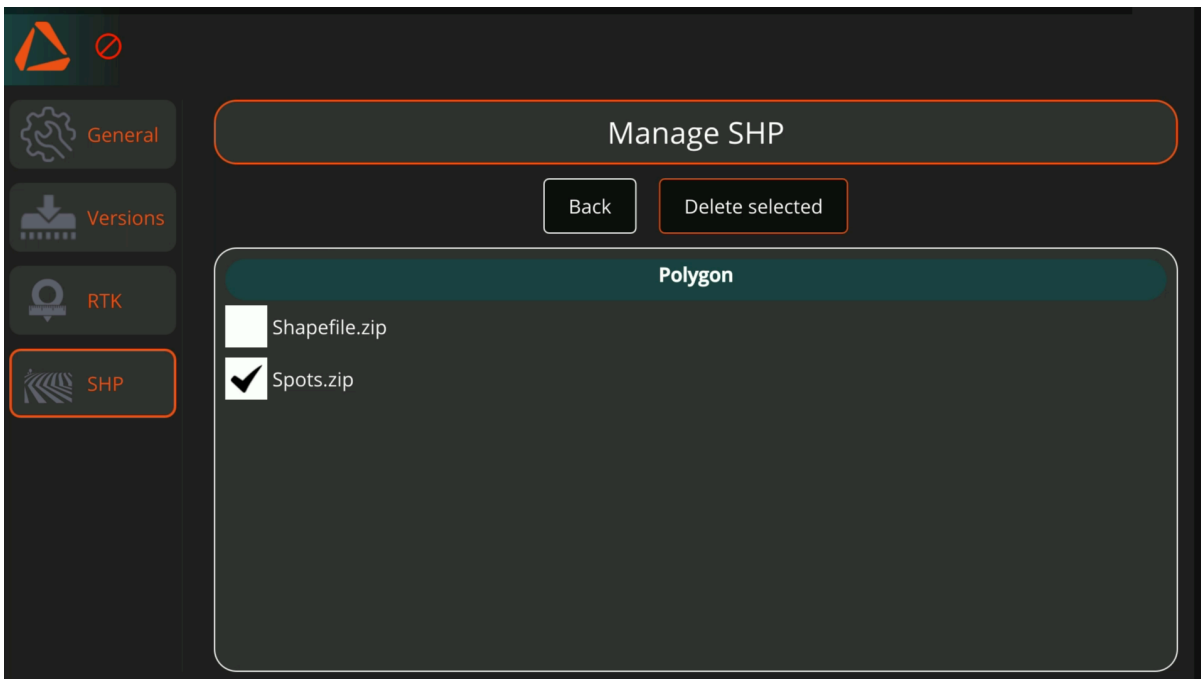

You can open the imported shapefiles to add them as a work area (polygon-based mission), a work route (polyline-based mission), or a visual guide:

- Imported **area shapefiles** can be selected in the ABZ Control app by clicking on Flight planning then selecting the **SHP/Area drawing** option on the Mission Planning Method Page. For further information on the use of a shapefile as an [area-based mission](#), see page 77.



- Imported **polyline (lineshape) files** can be selected in the ABZ Control app by clicking on Flight planning then selecting the **Advanced planning** option. For further information on the use of a shapefile as a [polyline based](#) mission, see page 78.
- For information on using shapefiles as [visual guides](#), see page 75.

Using shape files as visual guides

In ABZ Control, you can insert point, polyline, and polygon shapefiles as a layer to support precise planning. This function is available in the **SHP/Area Drawing** and **Advanced Planning** functions.



To open a shapefile as a visual guide, click on the shapefile icon . You can choose whether you want to use a point-, polygon-, or polyline-based shapefile as a Visual Guide.

After selecting one of the options, you will see the corresponding files previously imported to the controller.

Mark the needed file and click on Select File..

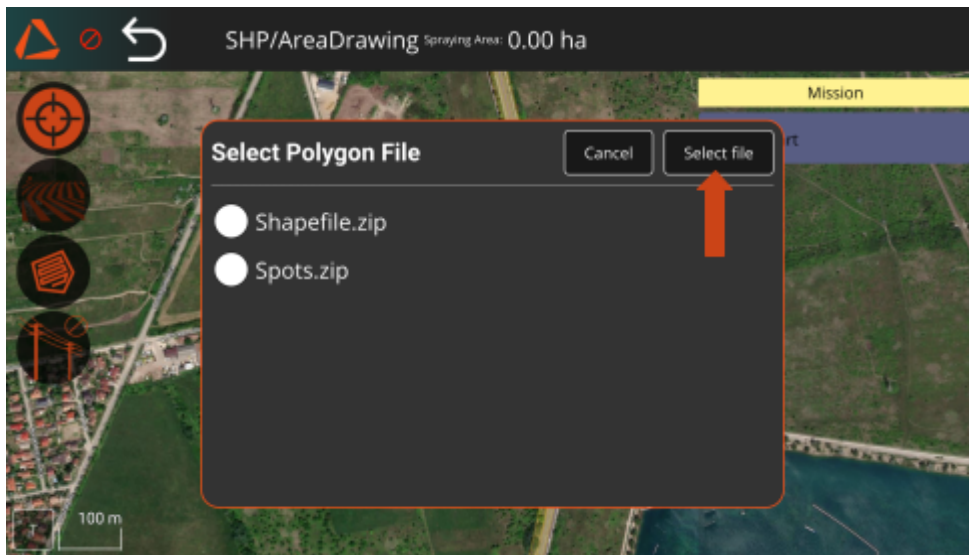

The shapefile will appear in the background, allowing you to use it for the precise placement of your boundary corner points (for more information about [Area Drawing](#), see page 75) or waypoints (for more information about waypoint-based [Advanced Planning](#), see page 58). It is possible to use multiple shapefiles of different geometry types simultaneously.

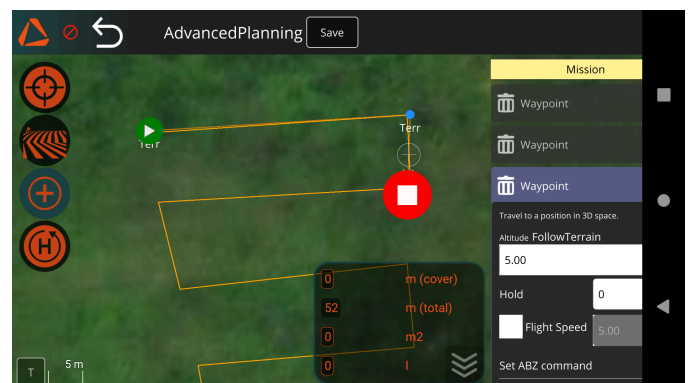
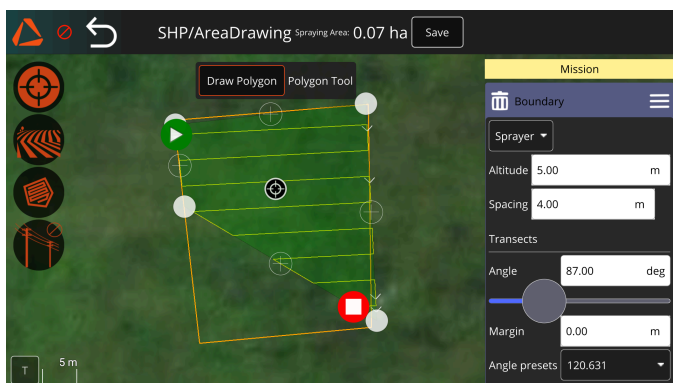

You can remove the visual guides from your planning page by clicking the Clear button.

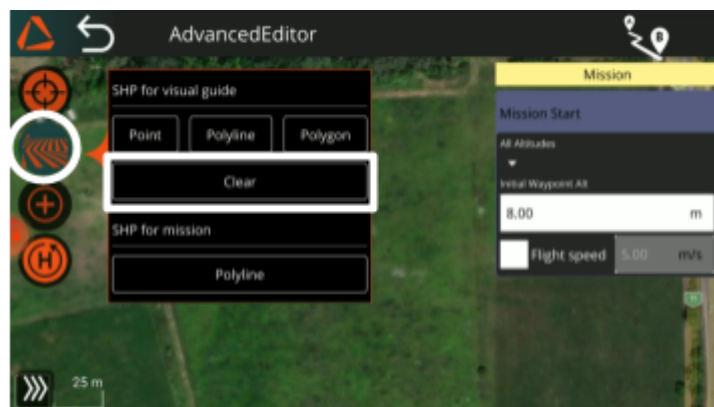

Planning the field by loading an area shape file

To use an area shapefile for planning, the files must be imported to the remote controller. [For further instructions](#), see page 78.

Open the **Planning view** and, on the **Mission Planning Method page**, select the **SHP/Area drawing** option.

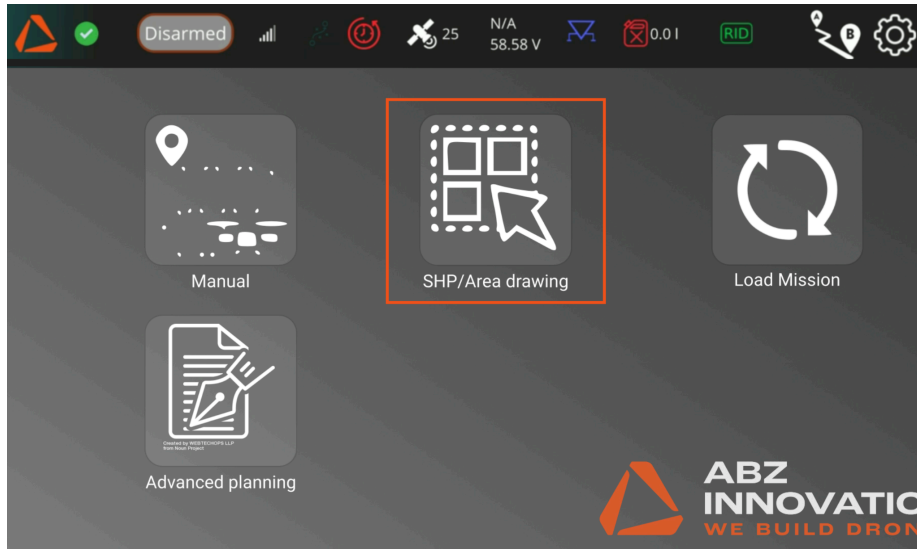

Click on the **Shapefile button** . In the pop-up window, under the **SHP for Mission** option, click on the **Polygon(s)** button.



In a popup window, you will see the corresponding files previously imported to the controller. Mark the needed file and click on **Select file**.

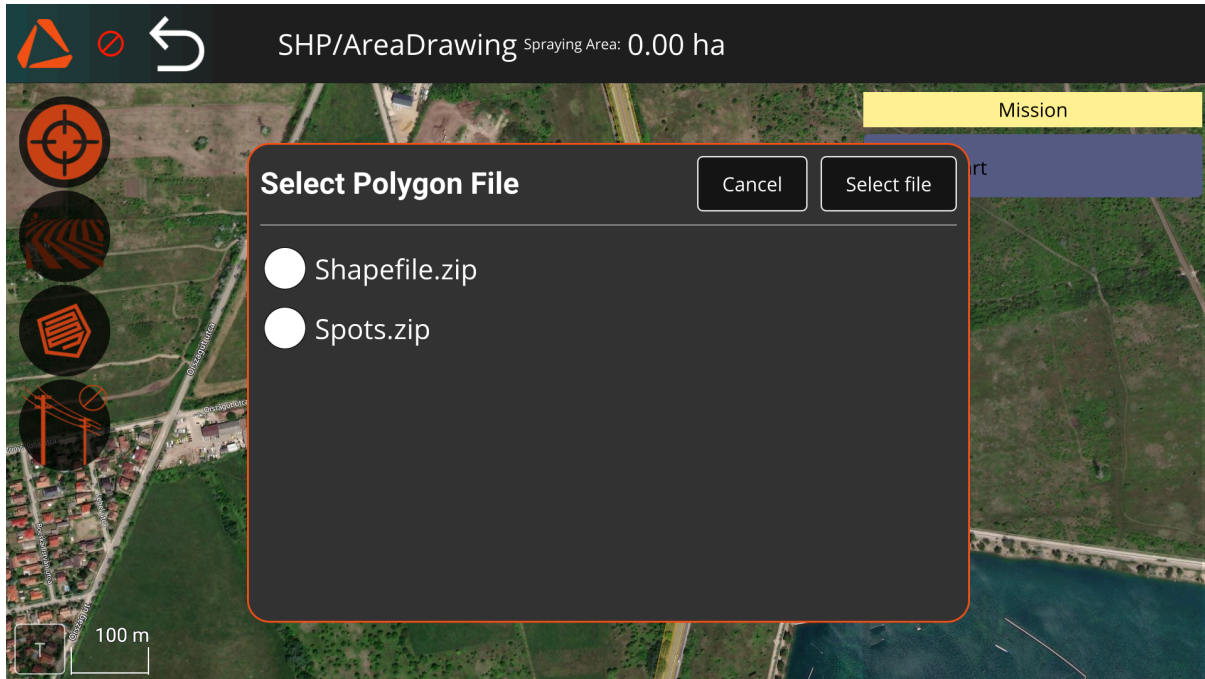

The polygon appears on the screen. If needed, you can adjust its edges by tapping and dragging the pins on the map.

To specify the [mission settings](#) for Area shapefiles, follow the instructions on page 86.

When you have finished editing, you can save the mission by clicking the **Save** button on the right side of the top menu bar. To upload the planned route to the drone, click the **Upload Required** or **Upload** button at the top-right corner of the screen.

To start the mission, navigate to the **Flight view** by clicking on the **ABZ Innovation logo**. If you leave the planning page by clicking on the back button, your plan will be cleared from the editor and from the drone. If you have saved your plan, the file remains on the controller and you can open it from the **Load mission** menu.

To start a mission, in the **Flight view** tap on the **'Start Mission'** button after manually flying the drone to a safe altitude. For more information on [how to fly a mission](#), see page 72.

Planning a mission by loading a Polyline (lineshape) file

The files must be imported to the ABZ Control (Settings > SHP). [For further instructions](#), see page 78.

To Load a Polyline mission in ABZ Control, you need to open the **Advanced Planning** from the **Mission Planning Method Page**.

1. In the **Mission Start** section of the right-hand Mission Panel, define the **Flight Speed** and the **Altitude Hold Mode** for your mission. Make sure to check the box next to the **Flight Speed** value; otherwise, the speed will not be applied.

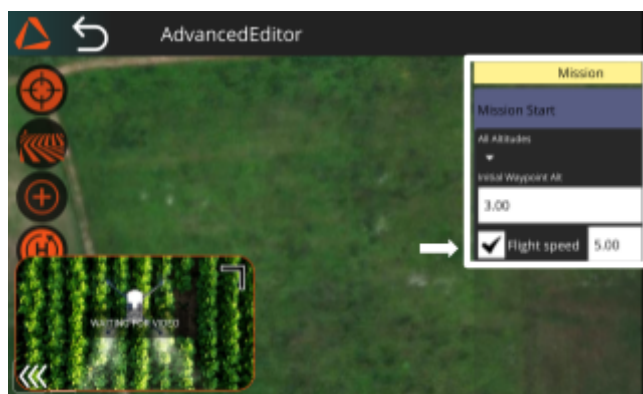

For **Altitude Hold Mode**, you have three available options.

(For further information regarding [Altitude control methods](#), see page 53):

- **Relative:** The drone's altitude will be relative to the takeoff point.
- **Follow Terrain:** The drone uses LiDAR to maintain altitude, measured as its distance from the ground. (only for drones equipped with LiDAR)
- **Mix Modes:** Allows applying the previous two modes individually for each waypoint.

2. On the right side, click the **SHP button** and, under the '**SHP for Mission**' section, click the **Polyline button**.

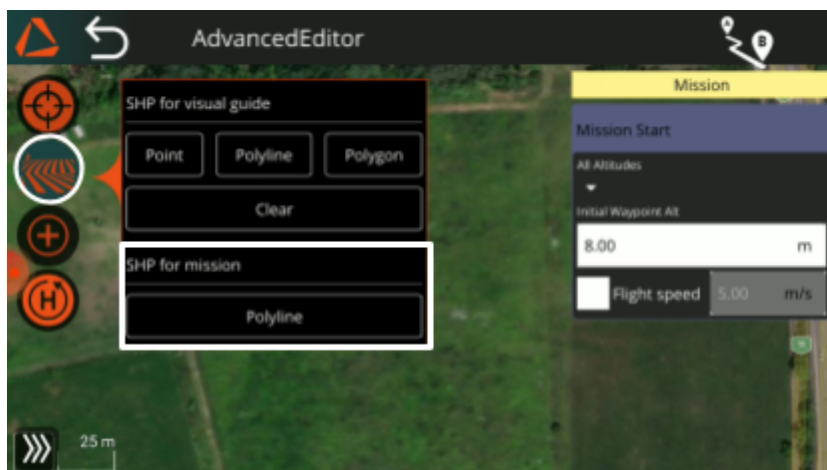

3. In the pop-up window choose the file you want to open and click on **Select file**.

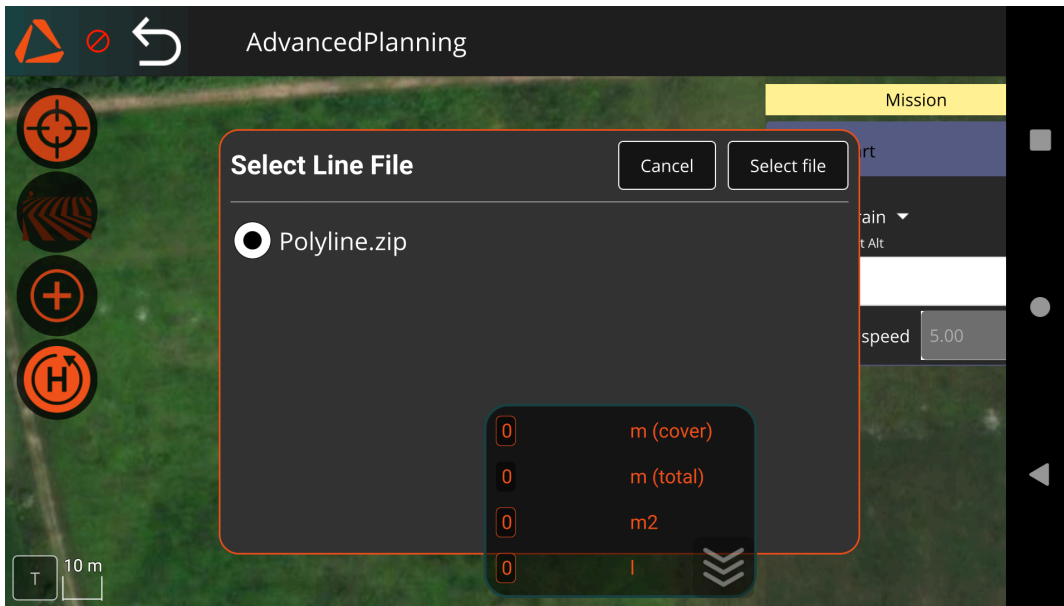

4. The editor will display the routes and waypoints on the map. The waypoints of the mission will be also listed in the **mission panel** on the right side. Here you can adjust the parameters for each waypoint, and delete them by clicking on the bin icon. If you change the settings for any waypoint, the subsequent waypoints will inherit the new setting.

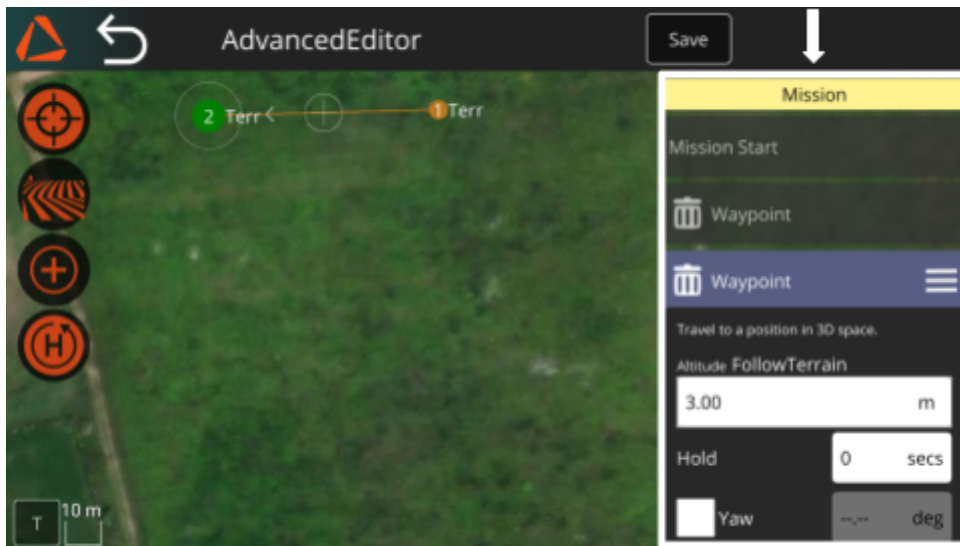

5. Click the arrow next to **Set Servos** to activate the payloads connected to, and associated with, the servos at the given waypoint.

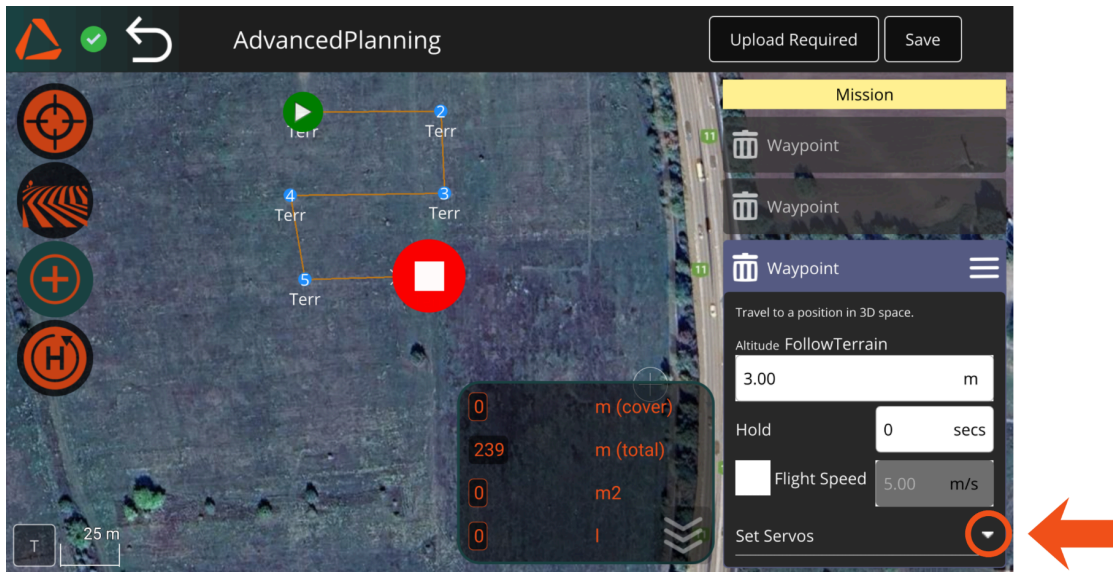

6. To activate a servo at a waypoint, select the box next to it and set the PWM value you want to use to control the payload.

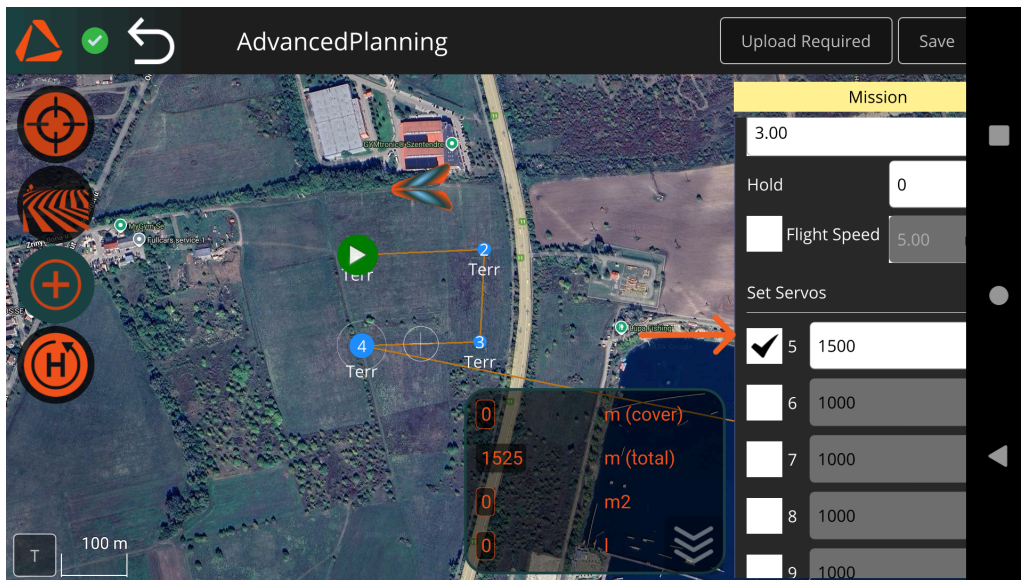

7. In the **Statistics Window**, after entering the mission parameters, you will see the calculated details of your mission:
 - a. Route with spraying activated (only relevant for L-series drone's)
 - b. Entire flight route
 - c. Area to be sprayed (only relevant for L-series drone's)
 - d. Required spraying liquid (only relevant for L-series drone's)

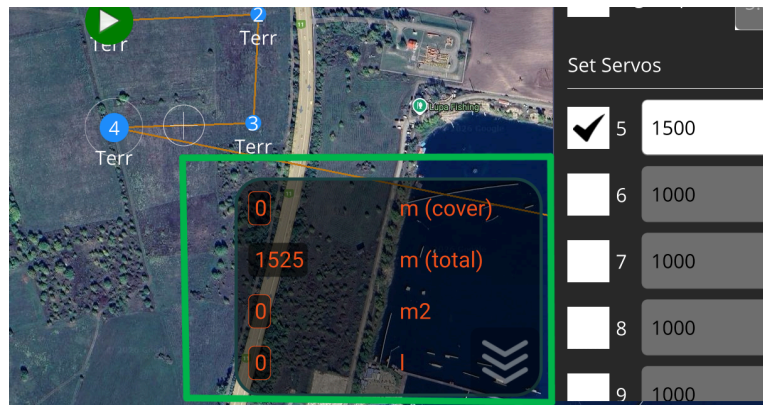

8. When you have finished editing, you can save the mission by clicking the **Save** button on the right side of the top menu bar. To upload the planned route to the drone, click the **Upload Required** or **Upload** button at the top-right corner of the screen.
9. To start the mission, navigate to the **Flight view** by clicking on the ABZ Innovation logo. In the Operation window, tap on the **'Start Mission'** button after manually flying the drone to a safe altitude. For further information regarding [starting a mission](#), see page 72.
10. If you leave the planning page by clicking on the back button, your plan will be cleared from the editor and from the drone. If you have saved your plan, the file remains on the controller and you can open it from the Load mission menu.

Loading a previously saved mission

If you have saved a mission plan using Manual, Drawing, or Advanced Planning, you can open it by clicking **Load Mission** on the Mission Planning Method page. These saved plans are stored on the remote controller and not on the drone.



After selecting a mission, you can adjust the [Mission Settings](#) in the Mission Panel, if needed (see page 70). When you have finished editing, you can save the mission by clicking the **Save** button on the right side of the top menu bar. To upload the planned route to the drone, click the **Upload Required** or **Upload** button at the top-right corner of the screen.

To start the mission, navigate to the **Flight view** by clicking on the ABZ Innovation logo. If you leave the planning page by clicking on the back button, your plan will be cleared from the editor and from the drone. If you have saved your plan, the file remains on the controller and you can open it from the **Load mission** menu.

To start a mission, in the **Flight view** tap on the '**Start Mission**' button after manually flying the drone to a safe altitude.

You can delete a mission by clicking on the hamburger menu next to the name of the Mission and choosing delete:

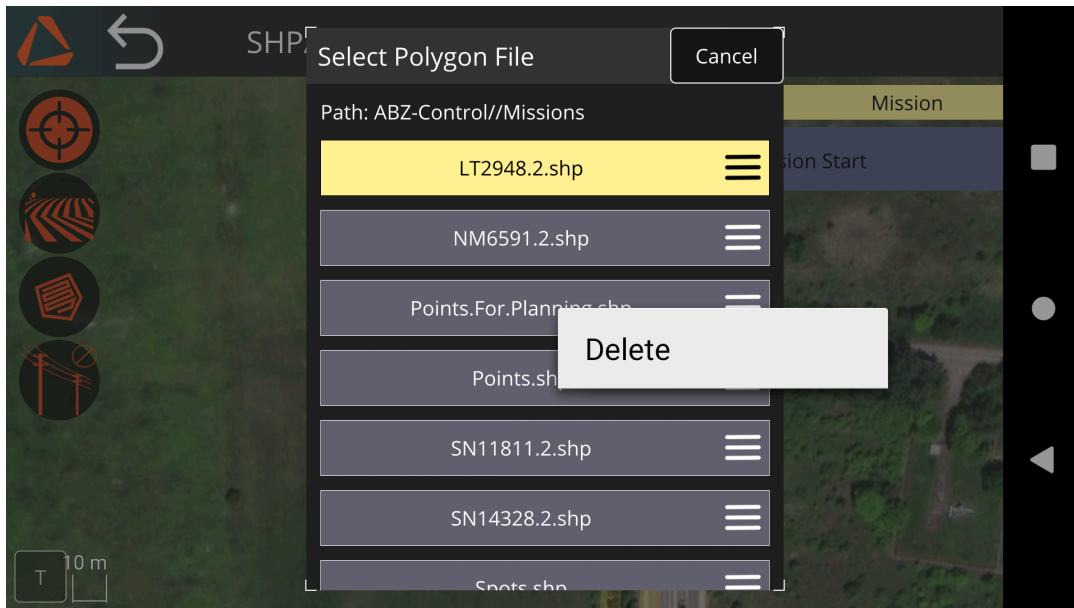

Flight

Before flight, check **Failsafe settings** and adjust them according to the actual flight task and surroundings.

When flying manually, use Manual (GPS-assisted) mode instead of AltHold whenever possible. In case of unexpected operation, switch to Loiter mode (pushing the A button) and release the sticks to stop the drone.

Set the display brightness in accordance with the lighting conditions. Every data on the display should be readable even in direct sunlight. Turn off unnecessary nearby Wi-Fi and radio equipment to minimize interference.

If all the necessary conditions for the flight are ensured, you can then enter the flight view to start the flight, switching to "Armed" mode.

In this software version manual take-off is required and manual landing is recommended.

After arming the drone, wait about 4 seconds for the motors to reach full speed before take-off. After manual take-off, start the automatic flight by sliding the Start mission - Slide to confirm button. Every flight must be carried out fully in accordance with all [Checklists](#) (page 104).



If any values must be adjusted in the Operations window > **Options**, even during the mission, these values can be adjusted. By default, the fields are greyed out. Check in the Editable box to turn on the editing option

After initiating the mission, a pop-up window appears to check all mission settings beforehand.



The automatic flight, and every other flight mode can be interrupted at any time by changing the flight mode, e.g. by pressing **Button A** (Manual mode - the drone will hover in position) or **Button B** (RTL – Return to launch) mode, the drone will fly back to the take-off position, so that settings can be modified, or the battery can be replaced.

After an interruption of automatic flight, the drone will offer you the Continue Mission option. By sliding the slider, the automatic route will continue from the point of interruption.

Irregular operational conditions

In case of any abnormal behavior of the drone during automatic flight, immediate switching to Manual (A button) or if enabled AltHold (C button) mode is required by the pilot to take full manual control and to ensure the safe flight and landing of the drone.

Please operate the drone smoothly when flying at low altitudes and fly above 3m.

If any flight system errors occur during the flight, the controller shows a pop-up message with information about abnormalities. If any of these happen, the pilot must take back manual control, switch back to **Manual** (Loiter) flight mode, and safely land the drone.

If the GPS system fails during flight, the "GPS glitch" pop-up message will be shown on the screen, and the pilot must land the drone.



In emergency situations, the pilot must operate the drone manually in the safest available manner, specifically taking care of personal and property security. The pilot must fly the drone away from potential risks, applying careful, slow stick inputs and flight speeds, find a safe area, and land the drone with a slow descent rate.

In case of a „Potential thrust loss” message, the pilot must land the drone as soon as possible, operating it with slow and smooth motion.

Brake mode

When you fly in **Altitude Hold** mode with the **Geocage** enabled, in rare scenarios, the drone can cross the boundary of the **Geocage**. This activates a safety protocol that switches the drone to **Brake mode**, and the drone stops at the boundary of the **Geocage**.

In **Brake mode**, the drone does not respond to control stick inputs, and you cannot activate the **Return to Launch** mode. To exit **Brake mode**, the pilot must switch to **Manual (Button A)** mode to get full control.

Error in Remote Identification System

The drone continuously monitors the Remote ID functionality from takeoff to shutdown and provides a notification of any malfunction or failure in the top bar of the ABZ Control application. If the Remote ID system detects an error during flight, the RID icon will turn red, and the drone will provide an error message stating that the Open Drone ID has encountered a problem (e.g., not receiving a location message).



If the Remote ID system experiences an error during operation, the unmanned aircraft is no longer broadcasting the message elements of the

standard Remote ID. The pilot must, in accordance with 14 CFR Part 89 (Minimum Performance Requirements for Standard Remote Identification of Unmanned Aircraft)⁴, land the unmanned aircraft as soon as practicable.

Declaring an Emergency

In the Remote ID interface, the pilot can click on the **Declare Emergency** button. To declare an emergency, you need to **press and hold the button for 3 seconds**. This function may be employed in situations such as loss of control, potential threats to persons or property, or in other emergency scenarios, at the pilot's discretion.



When an emergency is declared, the drone will broadcast the emergency status. To clear the emergency, press and hold the same button (which now displays the text 'Clear Emergency') for 3 seconds.



⁴ <http://www.fcc.gov>

Accessories

Payloads

ABZ Innovation does not limit the type of payloads to be used with the M12. Any properly and safely mounted and operated payloads are allowed to attach to, and use with the drone.

The operator is solely liable for using only properly secured, correctly connected payloads and accessories that are approved and compatible for drone use. It is the pilot's responsibility not to exceed the maximum combined weight of accessories, batteries, and payload, which is 13.3 kg (29.3 lbs), and not to exceed the MTOM of the fully equipped drone, which is 24.9 kg (54.8 lbs). To remain under 55 lbs (25 kg) in weight, the payload must not exceed 20 lbs / 9.1 kg.

The payloads significantly affect the drone's center of mass, especially, when heavy payload is mounted. It is highly recommended to install the payloads as close as possible to the drone's center.

If you have purchased different types of ABZ Innovation payloads (e.g., spreader or Trichogramma) and your drone is equipped with the necessary connectors, you can switch between them in the **Settings > Payloads** menu. The Payload Test switch will activate the selected payload using the test values defined in this menu.

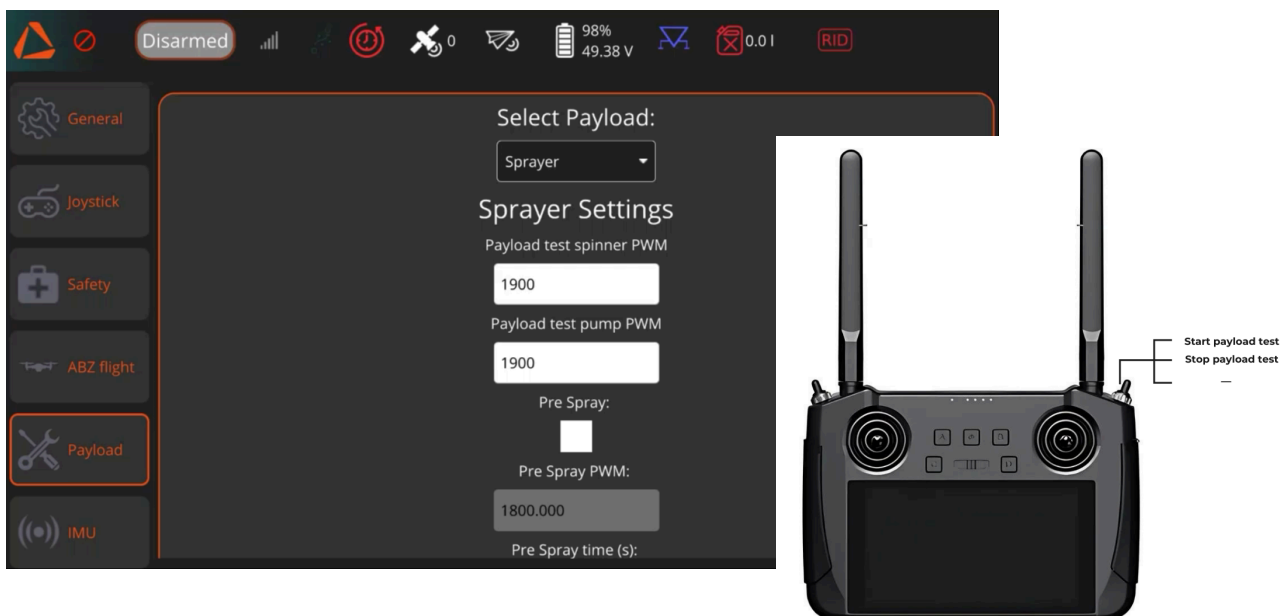

Emlid RTK

The M12 drone comes equipped with the Emlid LoRa system, which can be connected with Emlid RS+ or RS2+ RS3+ base stations for RTK positioning at centimeter precision.

An RTK base station is a high-precision GNSS (Global Navigation Satellite System) device used to provide real-time kinematic (RTK) corrections for enhanced positional accuracy. It works by receiving satellite signals and transmitting correction data to the drone.

Setting up the RS2+ or RS3 base is documented at Emlid's support pages:

- [Introduction | Reach RS3](#)
- [Introduction | Reach RS2/RS2+](#)

When setting up the RS2+ or RS3 base, make sure it is configured to **Output: LoRa**, and that the frequency entered in the **Setting > RTK > Lora radio module Emlid RS base station** matches the Base output value specified in the Emlid flow app.

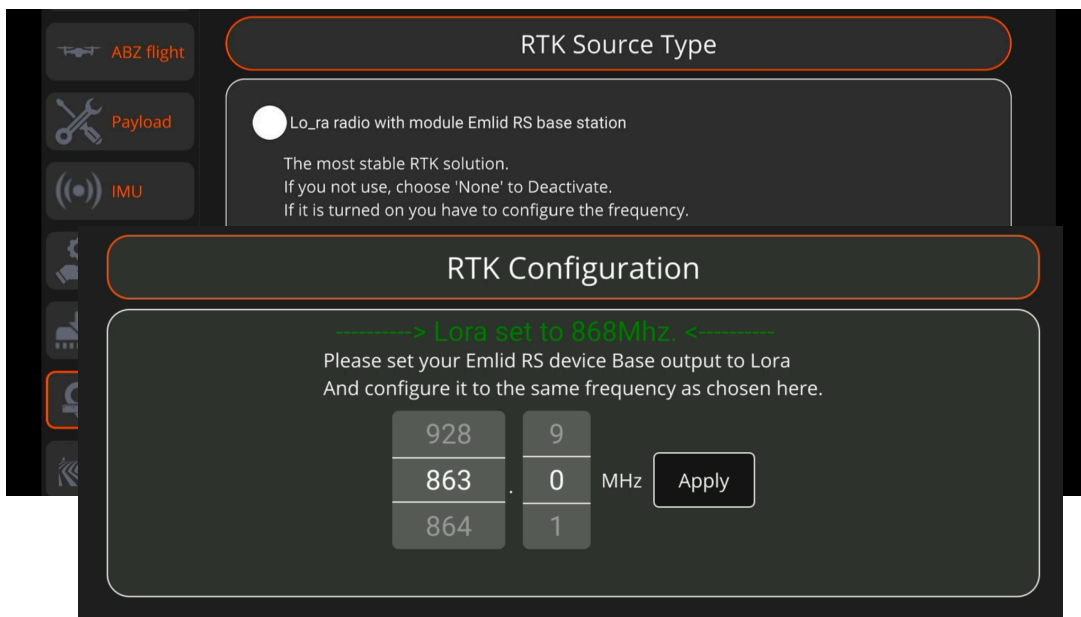

When the system is set up and working correctly, on the drone's controller the GPS Status shows the following based on the accuracy:

- GPS Lock – RTK float
- GPS Lock – RTK fixed

Batteries and chargers

Battery:

Only use batteries purchased directly from ABZ Innovation distributors! This ensures safe operations, full compatibility, and appropriate data connection to the drone. Using 3rd party batteries void the drone's warranty.

General information about the Smart Battery for L10/S20/M12/C10 drone (A001402.01):

- 43,5V nominal voltage
- min. 25000mAh capacity
- 25C discharge value
- 12 Cells
- Integrated Smart battery management system with automatic storage mode

Charger:

Only use the original ABZ Smart Charger 3000! This ensures safe charge, full compatibility, and appropriate data connection to the batteries. Using 3rd party chargers void the batteries' warranty.

- Power output: max. 60A/3000W
- Power Input: 16A/110-230V
- Capable of multiple charges at the same time
- Slow, Normal, Fast charge speed options. **Do NOT use the Fast mode!**
- Storage mode option
- To ensure long battery life, we highly recommend using balance charging.

Let the batteries rest after charging before using them.

For continuous drone operation, use a set of four batteries. In the field, you can charge two batteries simultaneously while operating the drone with the other two (one in use and one on standby).

Flight Protocol

Before flight, tasks and inspections

- Drone battery status (The state of the drone battery should be monitored before the flight using the charging indicator LEDs on the battery. We recommend starting the flight with a minimum of 80% battery charge).
- Visual inspection of the propellers, paying special attention to possible mechanical damage and whether the propellers are properly fastened.
- General inspection: cables, connections, video connection, payload, etc. Payload condition, arms, base structure condition, and whether the bolts are properly tight.
- Determine the flight location.
- The task to be performed is properly analyzed.
- Permits applied for and obtained.
- Tools and accessories needed for the work are prepared.
- The pilot is fit and ready to work.

Before take-off, tasks and inspections

- Weather conditions are suitable for the task: no lightning, appropriate temperature, visibility, rain, wind speed, etc.
- General visual inspection and condition assessment of the drone.
- Whether the drone is placed on level ground, away from metal surfaces.
- All batteries charged and checked: radio station, drone, video equipment, and accessories.
- The state of the drone battery should be monitored before the flight using the charging indicator LEDs on the battery. We recommend starting the flight with a minimum of 80% battery charge.
- The drone and all its accessories are in clean condition.
- The landing gear and any accessories are securely fastened.
- Unfold the drone's arms and tighten the fasteners,
- Unfold the propellers symmetrically
- The propellers are clean, undamaged, properly fastened, and positioned.
- The remote controller is switched on and correctly set. The remote controller must ALWAYS be switched on before the drone battery is connected.
- Check the radio, telemetry, and video antennas.
- NEVER leave batteries connected for prolonged periods.
- Before arming the drone, leave enough free space, stand at least 10 m (35 ft) away from it.

- Perform compass calibration if necessary.
- Check the video signal on the display.
- Check that the devices installed are working properly.
- Make sure that the task you have chosen is the one you want to carry out, is planned, and properly analyzed.
- Whether the take-off zone is sufficiently cleared.
- Arm the drone and take off.

After take-off, tasks

- Stabilize and hold the drone at a height of at least 3 m/9.8 ft.
- Test the left and right rotation functions, forward/reverse movements, right, left tilting.
- Check that the drone is stable and that there are no abnormal vibrations.
- Check the voltage of the battery.
- Start the mission with the drone

During mission, tasks

- Regularly check the voltage and charge level of your batteries.
- Check the flight altitude and the maximum allowed distance.
- If the drone or remote controller battery is low, land the drone in a safe place.
- During the flight, the pilot must monitor the battery voltage, which should always be above 43,5V, even when flying with the Maximum Take-off Mass (MTOM).
- Battery voltage below 43,5V:
 - start returning and landing the drone.
- Switch off the engines after landing (disarm function)
- End of mission.

After landing, tasks and inspections

- Switch off professional equipment if necessary.
- Switch off the drone by unplugging the battery from the connector.
- Switch off the remote controller.
- Clean the drone thoroughly (batteries, tools, camera, etc.).
- Disassemble, clean, check, and store all professional equipment properly.
- In the flight log, record the flight and any significant events. Accurate completion of this document is mandatory to monitor the operation and lifetime of the drone, and to facilitate properly scheduled servicing (every 300 flight hours).
- Record the nominal voltage remaining in the batteries used.

- After returning from the field, remove the batteries from the storage box and store them in a cool and well-ventilated place.
- DO NOT STORE batteries overcharged or fully discharged for extended periods of time.

Checklists

Before first take-off

- General structural, mechanical inspection
- Inspection of propellers one by one, even if there is only minor damage, takeoff is prohibited.
- Tightness of the drone arms' fasteners
- Propellers in an unfolded state
- Switch on the remote controller, and launch the ABZ Control app.
- When ABZ Control is waiting for the connection, turn on the drone by connecting the battery (the plug must be fully plugged in).
- If you are operating the drone in a country where the remote identification of drones is mandatory, verify in an appropriate application that the Dronetag DRI is correctly broadcasting your [Remote ID](#) (see on page 14).

Before every take-off

- Drone battery charge level. The state of the drone battery should be monitored before the flight using the charging indicator LEDs on the battery. We recommend starting the flight with a minimum of 80% battery charge.
- Remote controller battery charge level
- When ABZ Control is waiting for the connection, turn on the drone by connecting the battery (the plug must be fully plugged in).
- Check the connection between the remote controller and the drone.
- Verifying Telemetry live data (e.g. LiDAR, power consumption) (in case of failure, ABZ Control must be restarted).
- Whether the drone is in Manual (Loiter) mode (if not, press button A to switch).
- The drone is in Manual mode (if not, press button A to switch).
- You are at a safe distance (at least 10 m / 35 ft) from the drone.
- Switch to "Armed" mode by pushing the left control stick to the down-right position, until „Armed” is shown on the display, then releases the stick.
- After arming the drone, wait about 4 seconds for the motors to reach full speed before take-off.
- Take off to a safe height (at least 3 m / 9.85 ft).

After take-off

- Compass adjustment by a single 360° rotation around the vertical axis of the drone
- Check the stability and motion of the drone.
- Check the battery status and voltage frequently during flight.
- If the drone or remote controller battery is low, land the drone in a safe place.
- During the flight, the pilot must monitor the battery voltage, which should always be above 43.5 V, even when flying with the Maximum Take-off Mass (MTOM). It is recommended to start returning the drone when the battery is at 43.5V.
- The ABZ Control battery indicator icon serves only as an indicator and shows an approximate value.
- Land the drone carefully and at a safe descent speed.

After landing

- Switch to „Disarmed” mode by pushing the left control stick to the down position, until „Disarmed” is shown on the display and the motors are completely stopped.
- At the end of the flight, first switch off the drone and then the remote controller.
- The drone can then be folded for transport, make sure that the arms' fasteners are not in contact with the arm holder „C” clamps.

Troubleshooting

If any malfunction is experienced, contact an ABZ Innovation service center for further instructions. No repair attempts are allowed by the pilot or operator.

abzinnovation.com/authorized_services/

Replacement parts

Only original replacement parts are qualified, directly from ABZ Innovation.

There are no life-limited parts of the drone, however propellers and motors must be inspected frequently and in case of abnormalities, replacement is needed.

Other than replacing the propellers and the battery, every repair or replacement should be carried out only at an official ABZ Innovation distributor's service center by a trained and qualified technician. Never repair any parts of the drone while it is powered on.

List of spare parts and part numbers:

- Battery: A001402.01
- Propeller CW: M001233.01
- Propeller CCW: M001234.01

Replacing the propellers:

Tools for replacement:

- HEX 4 key
- Threadlocking fluid (e.g. Loctite 243)
- Original ABZ Innovation M12 propellers

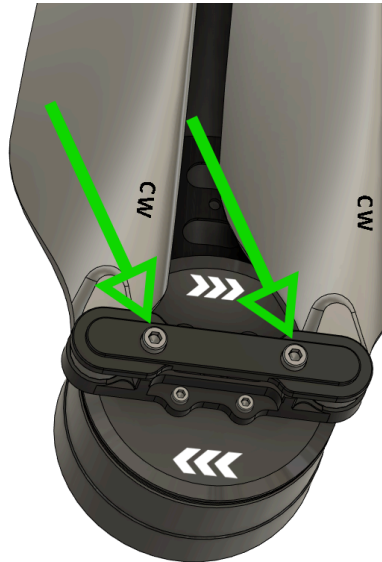

Carefully check the motor and propeller rotational direction. On the motors it is indicated with arrows, on the propellers „CW” or „CCW” are indicated.

1. Unscrew the two 4mm HEX screws,
2. Disassemble the fixing cap of the propellers
3. Remove the propeller's upper washers.
4. Remove the propellers and install new propellers.
5. Reinstall the upper washer and fixing cap.
6. Clean the 4mm HEX screws from threadlocking residues and apply new threadlocking material (according to the manufacturer's instruction).
7. Tighten the screws until the propellers have zero axial and radial play, but still easy to fold and unfold them.

Compass calibration

Compass calibration can be performed under **Settings > IMU > Compass**.

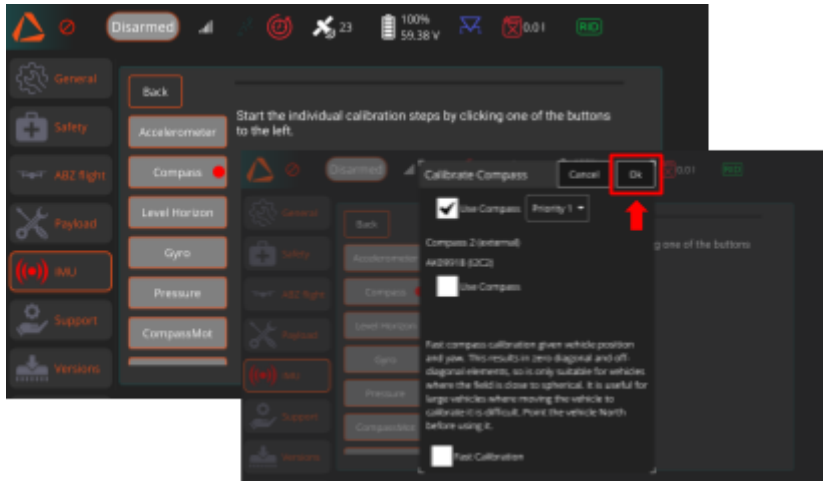

The calibration should only be performed if requested by the software or instructed by the Support Center. Do NOT use Fast calibration!

- The drone must be turned on, in „Disarmed” state.
- Remove any metal (e.g. keys, coins) and electronic object from your pockets.
- The calibration sequence is initiated by pressing the "OK" button.
- Hold and Rotate the drone by hand 360° around all axes, and in both rotational directions
- Until the status bar is complete (usually a 1-2 minute operation).
- The result of the calibration is shown by the calibration quality feedback:

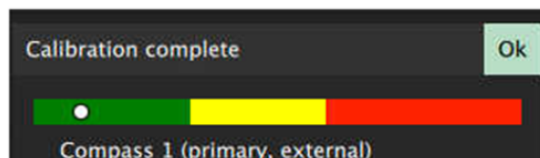

- Green: good quality calibration
-> Only green means successful calibration!
- Yellow: medium quality calibration; please recalibrate
- Red: not acceptable; please recalibrate

After the calibration is complete, do NOT press the Restart button on the interface. Instead, click OK. Wait for the green progress bar to finish loading, then restart the drone by powering it off and on using the battery button (short press followed by a long press).

General Information	1
Specifications	5
Packing list	6
Safety requirements	7
General Failsafe	12
Battery Failsafe	12
Mandatory Remote identification with Dronetag	14
Declaring an Emergency	17
Remote Controller	18
Network settings	22
Internet connection	23
Controlling the drone	24
Default control (mode 2)	28
ABZ Control Software Overview	29
Settings	38
Safety – Setting up FailSafe	40
RTK configuration	43
Adjusting the Obstacle Avoidance Options (only for drones equipped with LiDAR)	46
Additional Settings in ABZ Flight	47
IMU - Compass calibration	50
Software versions and Update	50
ABZ Sense (only for drones equipped with LiDAR)	51
Obstacle Avoidance with ABZ sense (only for drones equipped with LiDAR)	51
What to do if the drone stopped because of an obstacle?	53
Altitude control	54
Flight planning	57
Area based flight planning	66
To import a shapefile into ABZ Control:	79
Flight	94
Irregular operational conditions	96
Declaring an Emergency	98
Accessories	99
Payloads	99
Emlid RTK	100
Batteries and chargers	101
Flight Protocol	102
Before flight, tasks and inspections	102
Before take-off, tasks and inspections	102
After take-off, tasks	103
During mission, tasks	103
After landing, tasks and inspections	103
Checklists	105
Before first take-off	105

Table of contents

ABZ Innovation M12

Before every take-off	105
After take-off	106
After landing	106
Troubleshooting	107
Compass calibration	110

If you have any questions, please contact us: support@abzinnovation.com

ABZ Innovation Ltd. - www.abzinnovation.com