

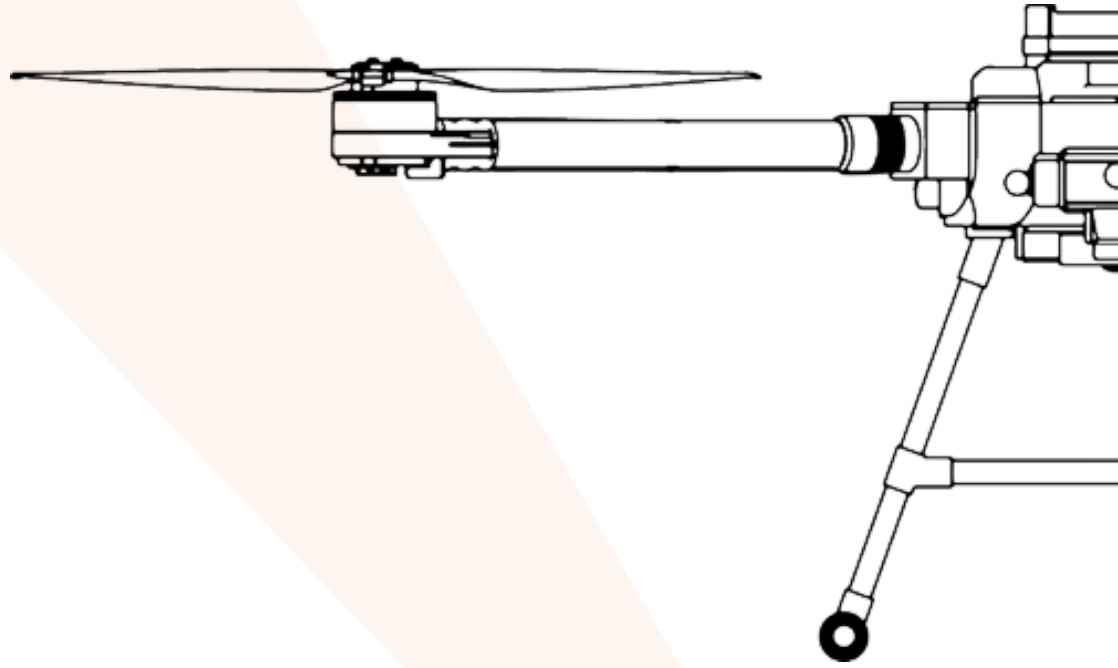

**ABZ**  
**INNOVATION**  
**WE BUILD DRONES.**



**C10**

**OPERATOR MANUAL**

Version 2.4

## General Information

### Overview

This manual is for the ABZ Innovation C10 cleaning drone, which can be upgraded with a high-pressure washing machine pipe as its payload.

The drone and its accessories may only be operated in accordance with the instructions in this manual.

Please read this notice and the manual provided for your ABZ Innovation C10 drone before use. If you have any questions, please contact ABZ Innovation customer service before use. The contact details can be found at the end of this document. By using the drone, you declare that you have read this manual, that you understand and acknowledge the information contained herein, and that you consent to use the drone only under proper conditions, in full compliance with applicable laws and the instructions in this manual. Furthermore, you agree that you are now exclusively responsible for the drone and its operation, and for any direct or indirect legal consequences arising from its operation.

The ABZ Innovation C10 drone is NOT a toy and is to be used only with care. The ABZ Innovation C10 is a technical, industrial device. Improper use of the drone poses a serious risk and can cause damage to the drone and its surroundings, severe personal injury or death. The drone may only be used by qualified pilots. For optimal efficiency and safety, the drone should be operated by a team of two people.

Any modification to the drone, its components or software will immediately void the warranty.

The drone can be purchased either as a standalone unit or equipped with the high-pressure washing system supplied by the manufacturer.

Customers must ensure that any chosen washing system complies with the drone's technical parameters. Failure to do so may result in operational failure, physical damage to the drone, and increased risk of personal injury.

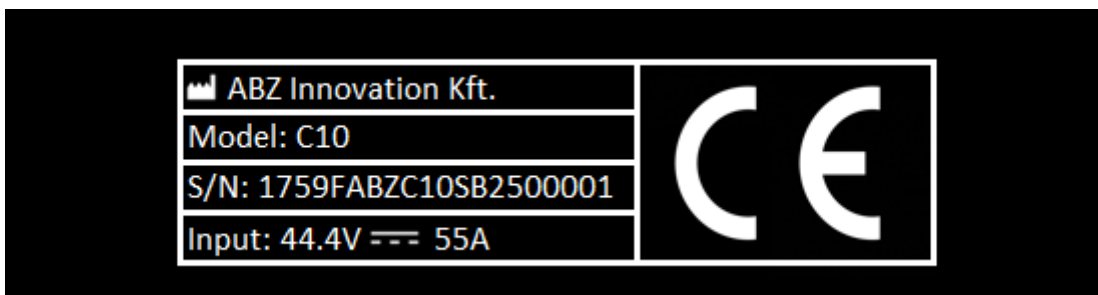
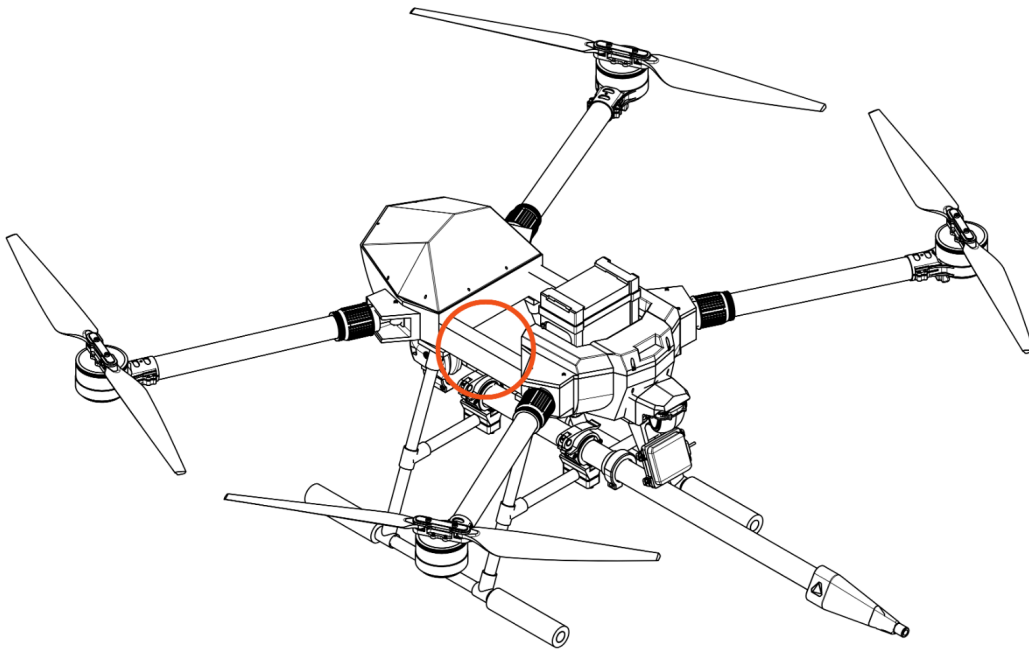

To identify a C10, locate the serial number label on the right side of the drone frame and check if the „Model” is C10.

## Drone main parts

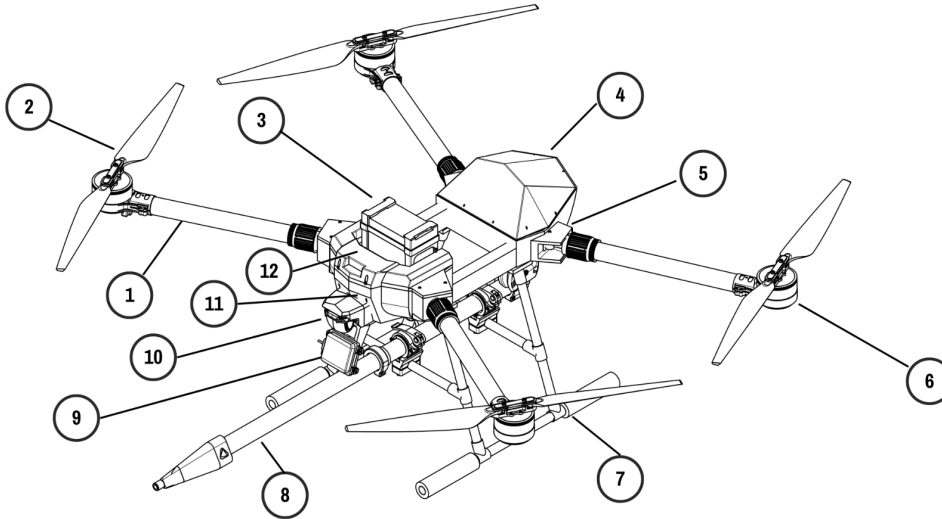

1: Arms

2: Propellers

3: Battery

4: Rear cover

5: RC antennas

6: Motor

7: Landing gear

8: Cleaning lance

9: Radar

10: Camera

11: Front cover

12: Battery connector

The high-pressure washing system provided by the manufacturer is fully optimized for the drone's capabilities. The water-filled hose remains within the approved payload limits, and its length supports effective operation at washing heights of up to 60 meters.

Customers must ensure that any chosen washing system complies with the drone's technical parameters. Failure to do so may result in operational failure, physical damage to the drone, and heightened risk of personal injury.

## Packing list

The C10 drone standard package contains:

- C10 drone
- Drone lance
- Standard and tilting nozzle holder
- ABZ Innovation MK15 remote controller with sticks and antennas
- 20 W fast charger and cable for remote controller
- US/EU plug converter for the fast charger
- USB-C / USB-A converter
- Carrying case for the remote controller

## Specifications

UAS category classification	C5 <b>(valid only for the C10 drone as a complete system)*</b>
Max. Take-off Mass (MTOM)	24,9 kg
Drone empty weight	11,75 kg
Max. payload weight (Includes the maximum weight of the pipe that can be lifted. The pilot should consider the water's weight inside the pipe.)	8,95 kg
Max. summarized weight of accessories and batteries and payloads	13,15 kg
Battery weight	4,2 kg
Dimensions arms, propellers unfolded	1460 x 1020 x 610 [mm]
Dimensions arms unfolded, propellers folded	1380 x 940 x 610 [mm]
Dimensions arms and propellers folded	780 x 500 x 610 [mm]
Flight precision	GPS/RTK
Battery integration	Quick connector
Drone frame	Folding frame
Range of RC	3,5 km
Flight speed (working)	3m/s
Airspeed (maximum)	13m/s
Max. tolerable wind speed	10m/s
Radio Control and Telemetry band	2,4 GHz
Radio Control Telemetry Power	20 dBm
Method of Modulation	Frequency
WLAN frequency band	2,4 GHz

**\*The C5 category classification is valid only for the C10 drone as a complete system, including the spray lance (P/N:P001420.01) with the hose installed and provided by ABZ Innovation, and the 30 m (P/N: A001175.01) and 60 m (P/N: A001176.01) hoses supplied by ABZ Innovation.**

## Safety requirements

## Child protection provisions

- This equipment is not suitable for use in places where children are likely to be present.
- The equipment must be kept out of the reach of children.
- The equipment operates rotating parts that are dangerous for children and must be kept out of the reach of children!

## Operating conditions

- For optimal efficiency and safety, drones should be operated by a team of two people.
- It is forbidden to operate the drone or any of its components in an enclosed space.
- In all flight modes including take-off and landing, the pilot must comply with all safety requirements and the technical conditions must be met.
- Do not fly over or near people.
- When recording a video or picture, the privacy and property rights must be met. Recordings are only allowed with authorization of every involved person, including private property.
- The operator must use a Drone Remote Identification (RemoteID) device to comply with legal requirements.
- Maintain flight altitude below 60 m above ground level.
- Fly only in moderate weather conditions, between temperatures of 5°C and 45°C (41°F and 113°F).
- Do not fly in rain, hail, or in higher relative humidity than 80%.
- Avoid contact with any solid objects or animals during flight, even smaller particles (excessive sand, dust, or swarm of insects) can cause damage to the propellers, when contacting at high (rotational) speed.
- The pilot must ensure that during the entire flight, VLOS conditions are assured. Flight in excessive fog, dust, etc. is prohibited.
- In dark lighting conditions the pilot must reduce the maximum flight distance to a limit, where the drone and its orientation is safely determined based on the light of the LEDs.
- Your flying activities must not violate any applicable laws or regulations. You must have all necessary permits. Contact the appropriate government agency or authority before flying to ensure that you are operating your drone in compliance with laws and regulations.

## Operation

- The drone may only be switched on and operated in accordance with the "Flight Protocol" chapter starting on page 47.
- Only use the drone in full compliance with the checklists.
- Stay away from rotating propellers and motors.
- Do not exceed the maximum combined accessories and batteries and payload weight in any case. Otherwise, the drone may be damaged and the flight might pose danger.
- Always keep the drone within visual line of sight (VLOS) and keep an eye on it.
- Don't get distracted by using your mobile phone or any other activities.
- Don't fly under the influence of alcohol, drugs or medicines. Fly only when you are mentally and physically capable of safely controlling the drone, including paying attention to its surroundings.
- If the drone or remote controller battery is low, land the drone in a safe place. The state of the drone battery should be monitored before the flight using the charging indicator LEDs on the battery. We recommend starting the flight with a minimum of 80% battery charge.
- During the flight, the pilot must monitor the battery voltage, which should always be above 43.5V, even when flying with the Maximum Take-off Mass (MTOM). The ABZ Control battery indicator icon serves only as an indicator and shows an approximate value.
- Never fly closer than 100m of a high voltage power line or high-power radio emitters (e.g. Radar, TV/Radio station).
- After landing, switch off the motors, switch off the drone by disconnecting the battery, and then switch off the remote controller.

## Maintenance and storage

- Do not use damaged, broken, or aged propellers.
- Regularly check the condition of the drone and make a flight log.
- To avoid damage to the drone's landing gear, remove payloads, accessories and the battery before transportation.
- Clean the drone, especially the propellers, after use.
- Recommended storage temperature: between 5°C and 40°C (41°F and 104°F) applicable for the drone, as well as the remote controller and the batteries.
- Never store the remote controller or the drone's batteries below 0°C, it will cause excessive degradation to the battery cells.
- Store the drone, remote controller, and batteries below 60% relative humidity.
- The remote controller and the drone's batteries must be stored at about 60% charge.
- Batteries deplete after extended storage. The remote controller and the drone's batteries must be discharged and recharged every 3 months of storage.
- After long-term storage:
  - Every battery must be inspected and fully charged before use.
  - The drone's motors must be inspected for free rotation.

## Drone handling and use precautions

- Before commencing each flight, plan your drone's flight path with care and attention. Pay attention to the following:
  - working at a suitable time of day,
  - weather conditions,
  - environmental influences (such as sunlight),
  - drifting of the drone in case of wind,
  - wind speed,
  - flight altitude,
  - Make sure there are no obstacles in the work area between the pilot and the operated drone.

- The equipment is powered by a replaceable battery. Make sure the batteries are in good condition and fully charged. Do not use faulty or damaged batteries. To learn about proper use and storage, please read the battery's instruction manual.
- The batteries can be charged using an external battery charger. To use this, please refer to the battery charger's instructions for use.
- The battery performance varies by the temperature, always pay attention to this phenomenon and follow the battery's instruction manual. Operate or charge the batteries only between 5°C and 45°C ambient temperatures, while the battery's temperature remains between 10°C and 60°C.
- Battery discharge is not linear, depending on load, temperature, internal resistance, and condition of cells. This figure shows the typical discharge curve for a drone battery in 90% state of health, at 40°C at 7,5C load:

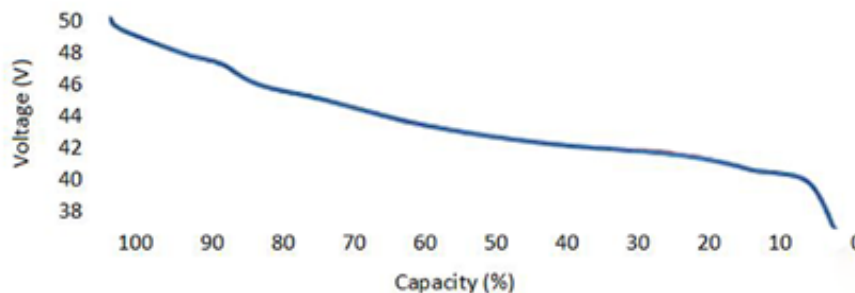

- The maximum masses of accessories/batteries/payloads combined, fitted to the drone must not exceed 13,15, thereby the drone's overall mass must not exceed the Maximum Take-off Mass (MTOM), 24,9 kg.
- The drone's maximum flight time with a single battery is primarily determined by its Take-off Mass, which is directly affected by the hose's filled length and the operational altitude. Under standard operating conditions, a single battery delivers approximately 18 minutes of flight time.
- Payloads—especially an attached lance—can significantly affect the drone's stability and maneuverability. Pilots should exercise increased caution, as these changes may result in slower response times during acceleration, braking, turning, and altitude adjustments.

### Information about transport

The drone is designed for outdoor work. The drone can be delivered to the site in the trunk of a vehicle, in the loading area of a truck, or in a trailer. Always apply the protective foam fixations to the propellers before moving the drone with folded arms. Proper anchorage is an important prerequisite for the safe transport of the drone, as it is done on uneven road surfaces and on various terrains. Securing the drone improperly can cause damage such as deformation and ultimately breakage of the propellers, damage, punctures, damage to the fastenings, payloads, etc...

Transporting the equipment requires extra care and attention. Improperly secured equipment and accessories necessary for its operation (drone, drone batteries, battery charger, generator, etc...) can lead to damage, which may ultimately lead to total equipment failure. Therefore, please carefully secure the drone during transport and store its accessories in a suitable place.

### In case of loss of signal and communication

The ABZ Innovation C10 drone's software is equipped with safety features that ensure safe operation at all times. These include possible loss of signal and communication. This can occur when the drone signal is out of range, obstructed by a hill or building, or affected by interference from nearby equipment, electronic devices, or magnetic sources. In these cases, the drone will communicate clear instructions to the operator while the software initiates safety functions.

If the drone loses signal from the remote controller, or the communication between these are interrupted, on the remote controller's screen the following message will appear: „COMMUNICATION LOST” and it will read it out loud (if the volume is not muted).

The drone and the remote controller will try to recover the connection automatically. However, if possible, it is highly recommended for the pilot to move the remote controller closer to the drone, especially if any obstacles (e.g. building, tree, or a hill) are in between.

In the event of a crash, the drone typically disarms itself. However, if the rotors are still spinning, the pilot should attempt to activate the Motor emergency stop (by pressing the C and D buttons simultaneously), even if the 'Communication Lost' message is displayed.

**Never approach an armed drone!**

## Operational Safety

Understanding the environmental and equipment-related factors that can impact your C10 washing drone's performance is crucial for safe and effective operation.

**Due to the emergency push function, it is dangerous to attempt take-off or landing with the Automatic Distance Control System activated. Never arm the drone, attempt to take off, or initiate landing while the system is active (status: ON).**

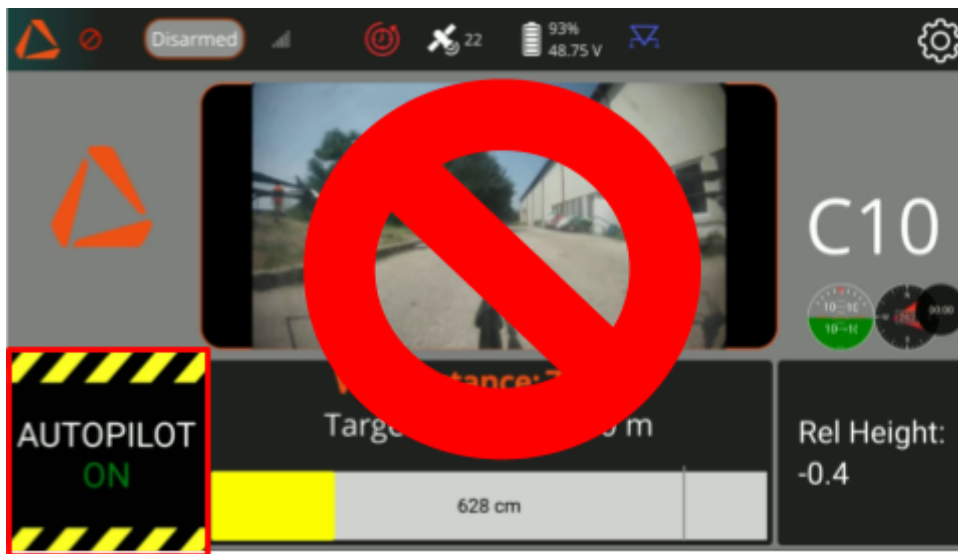

- **Always** ensure that the system is in the Disabled or OFF status before arming the drone and taking off. Before landing, always turn OFF the Automatic Distance Control System by setting the right-side 3-position switch to the up position.
- **Drone Stability in Wind:** While the C10 platform handles constant wind speeds well, strong gusts can displace the drone by 10-30 cm before it can compensate. Always account for this potential instability. For optimal conditions, you should operate in calm weather or with light, steady winds. The recommended wind strength is less than 30 km/h.
- **Water Jet Focus in Wind:** Increasing wind speeds significantly weaken the focus of the high-pressure water jet. In windy conditions, the cleaning effect becomes ineffective at distances beyond 20-30 cm from the nozzle. If you observe this loss of focus, the wind speed is too high for safe operation. You must immediately stop the washing process.
- **Wall Surface Integrity:** Leaky, broken, or incomplete wall surfaces can weaken the radar signal, which can negatively impact the drone's automatic distance-keeping capabilities. As a solution, if radar-based ranging becomes unreliable, an experienced pilot may need to switch to manual flight operation.

- **Protruding Obstacles:** Be aware of any obstacles protruding from the wall surface, such as vents, signs, or structural elements. These can interfere with the drone's flight path or entangle the hose.
- **Hose Entanglement:** Hose entanglement during flight is a significant safety hazard. The best practice is to ensure the hose is always free of knots and can move without restriction in all directions before and during operation.
- **Hose Weight and Altitude:** As the drone ascends, the increasing weight of the extended hose creates a greater downward force and can affect the drone's responsiveness due to inertia. To minimize this effect, it is recommended that operations stay below a 30-meter altitude.
- **Hose Position and Lateral Force:** The position of the high-pressure washing system on the ground relative to the drone can cause the hose to exert a lateral (sideways) pull. This can cause the drone to rotate unexpectedly, which is a safety hazard, especially when operating close to a surface.

For optimal positioning to minimize lateral pull, mark a 6-8 meter wide section of the wall to be washed and position the hose system in the middle of that section on the ground. Keep the drone within a +/- 3-4 meter horizontal range from the ground system's position as you move up and down the washing area.

## Mandatory Remote identification with Dronetag

For security reasons, remote identification of drones is mandatory in the United States and the European Union. All drones must be equipped with a Remote Identification device to locally transmit information about the operating drone.

The C10 V2 drone comes equipped with a Dronetag DRI Remote ID module and meets the requirements of the legislation of the European Union<sup>1</sup> and the United States<sup>2</sup>.

The Remote ID of your drone is its serial number, which is broadcast from the device during flight. The drone's system prevents takeoff if the Remote ID is not functioning.

The **RID icon** shows the operational status of the Remote ID system. If the icon is green, the Remote ID is broadcast correctly.

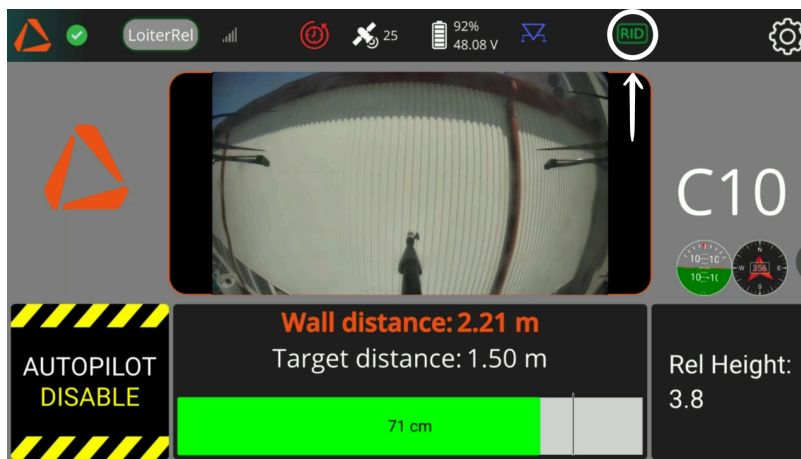

If the RID icon is red, it indicates that the Remote ID broadcast is not functioning properly.



<sup>1</sup> Commission Implementing Regulation (EU) 2019/947 (<https://eur-lex.europa.eu/legal-content/EN/TXT/?uri=CELEX%3A32019R0947>)

<sup>2</sup> 14 CFR Part 89 – Minimum Performance Requirements for Standard Remote Identification of Unmanned Aircraft (<https://www.ecfr.gov/current/title-14/chapter-I/subchapter-F/part-89>)

By clicking on the icon, you can check the health of the systems providing the necessary data for the Remote ID module.

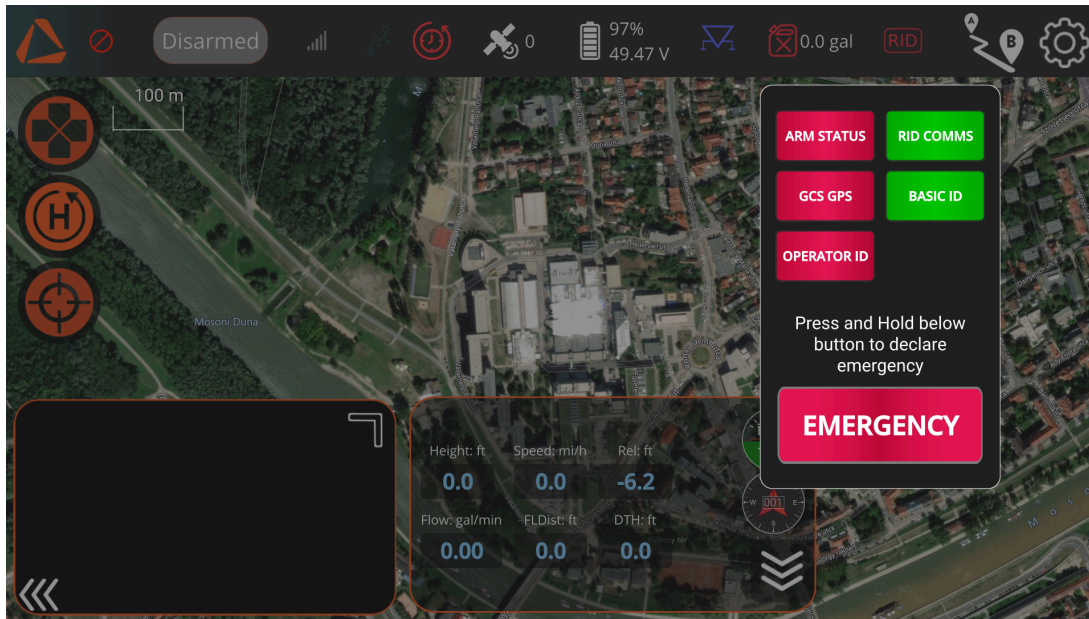

The **ARM STATUS** field provides feedback about the proper functioning of the location source hardware and software of the drone. In the case of a malfunction, this icon will turn red, and consequently, the Remote ID icon will also turn red, indicating a malfunction in the Remote ID system. The drone will also provide an error message stating that the Open Drone ID has encountered a problem (e.g., not receiving a location message).

The **GCP GPS** field provides feedback about the proper functioning of the Transmitter radio GPS (hardware and software). In the case of a malfunction, this icon will turn red, and consequently, the Remote ID icon will also turn red, indicating a malfunction in the Remote ID system. The drone will also provide an error message stating that the Open Drone ID has encountered a problem (e.g., not receiving a location message).

The **RID COMMS** field provides feedback on the proper connection between the Remote ID module and the drone.

The **BASIC ID** field should always be green, indicating that the drone's serial number has been set up as Remote ID and is broadcasting. **If the Remote ID system experiences an error due to insufficient GPS coverage on the drone or the remote controller, or a hardware malfunction, the drone prevents arming.**

The **Operator ID** field displays the status of the Remote ID being provided and broadcast in accordance with EU regulations. To enter your Operator ID, go to Settings > Remote ID. (See page 12).

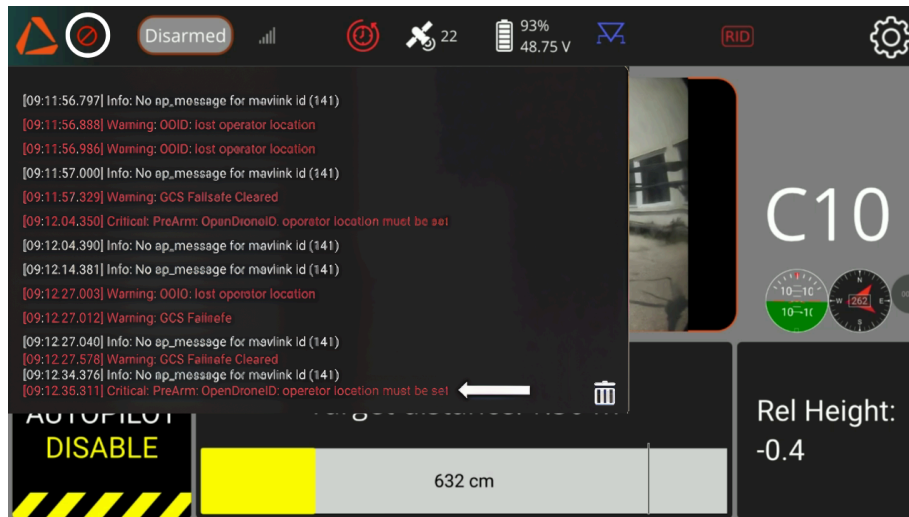

The drone continuously monitors the Remote ID functionality **from takeoff to shutdown** and provides a **notification of any malfunction or failure** in the top bar of the ABZ Control application. If the Remote ID system detects an error during flight, the RID icon will turn red, and the drone will provide an error message stating that the Open Drone ID has encountered a problem (e.g., not receiving a location message).

**If the Remote ID system experiences an error during operation, the unmanned aircraft is no longer broadcasting the message elements of the standard Remote ID.**<sup>3</sup>

<sup>3</sup> In the United States, the pilot must, in accordance with 14 CFR Part 89 (Minimum Performance Requirements for Standard Remote Identification of Unmanned Aircraft), land the unmanned aircraft as soon as practicable.

## Declaring an Emergency

In the Remote ID interface, the pilot can click on the **Declare Emergency** button. To declare an emergency, you need to **press and hold the button for 3 seconds**. This function may be employed in situations such as loss of control, potential threats to persons or property, or in other emergency scenarios, at the pilot's discretion.

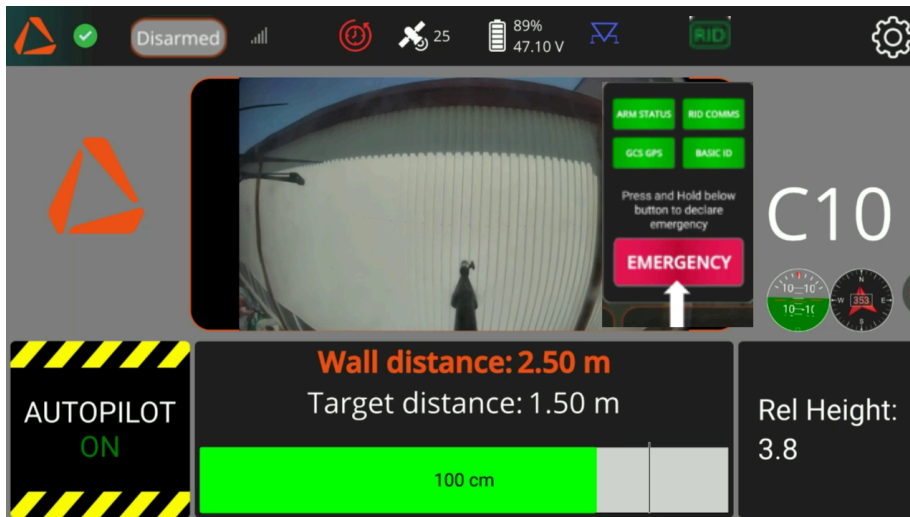

When an emergency is declared, the drone will broadcast the emergency status. To clear the emergency, press and hold the same button (which now displays the text '**Clear Emergency**') for **3 seconds**.

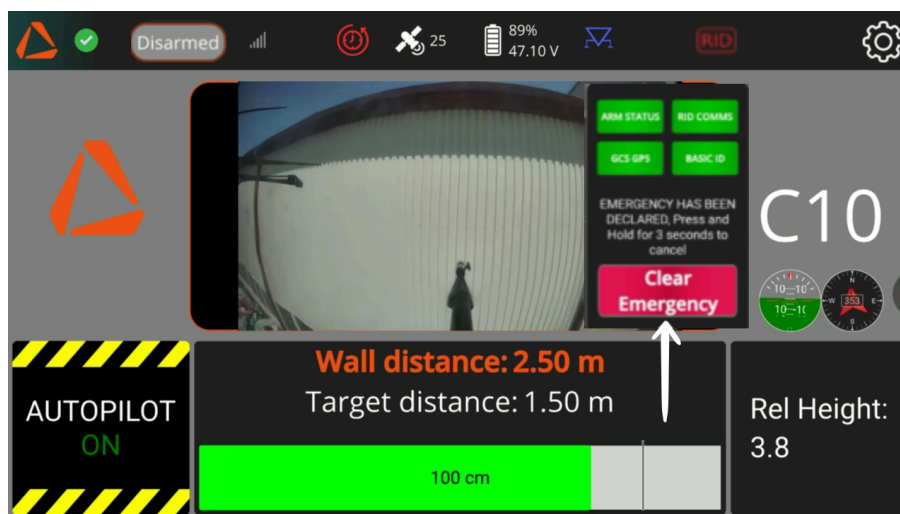

## Remote Controller

The C10 is compatible only with the controllers provided by ABZ Innovation with specialized ABZ Control software. Every firmware/software combination is compatible with the drone. The available remote controller unit:

- ABZ Innovation MK15

Other devices or applications are not compatible for controlling the drone, therefore prohibited to use with the drone.

The MK15 remote controller is an Android operation system-based device, with an integrated system for communicating through radio signals with the drone. It runs the ABZ Control application to control the drone and let the pilot access all telemetry data and advanced flight planning.

If the remote controller is turned off, you can check the battery charge of the remote controller by a short push of the power button. The blue LEDs indicate the charge level. The single LED in front of them gives feedback about the connection between the drone and the remote controller. When the LED is green, the drone and the remote controller are connected.



**To switch on the remote controller, push the power button once briefly and then once more for a longer duration (until you hear the system's sound signal).**

**You can only charge the remote controller when it is powered off and only with the supplied fast Charger. The RC cannot be charged while working.**

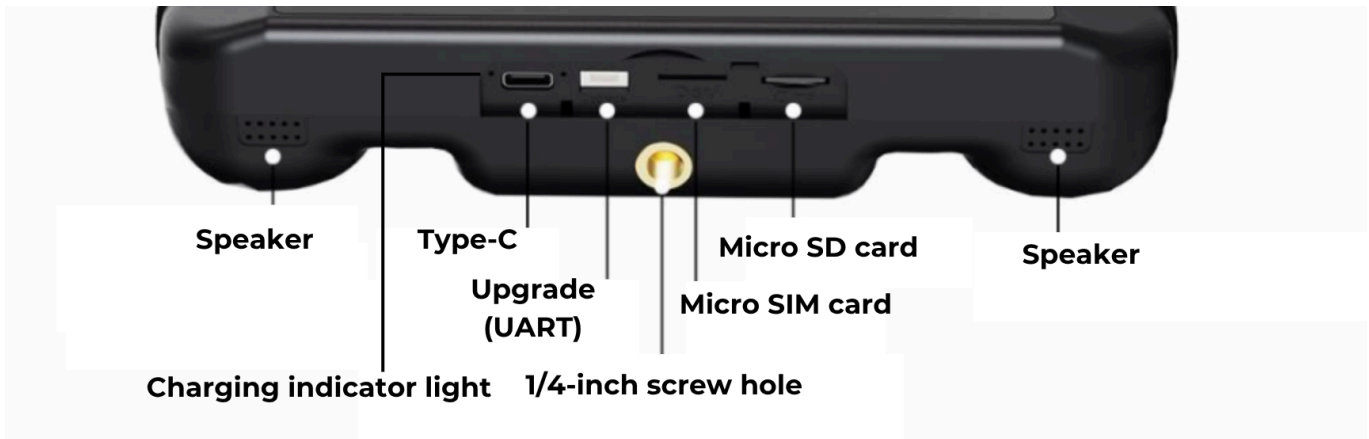

1. Connect the remote controller to the fast charger and plug it into the power supply.
2. The charging indicator lights are red when the ground unit is charging.
3. The charging indicator lights are green when charging is finished.

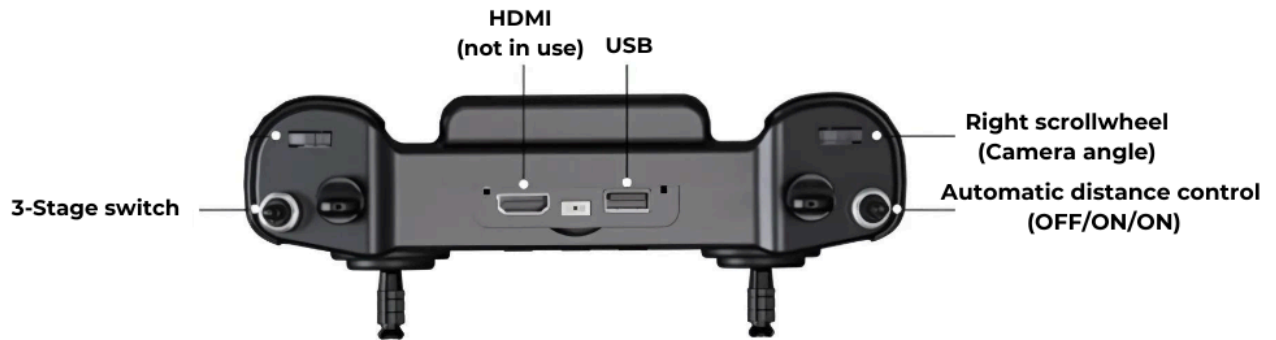

If you push the power button once short, the screen will turn off (power saving mode). If you push the button for 1 second, you can choose between the options of powering off the remote controller or taking a screenshot.

You can access the Android navigation bar by swiping down from the top of the screen or swiping from the right side of the screen.

The rectangular icon allows you to switch between applications. The circular icon takes you to the main screen. The triangular icon lets you go back to the previous screen (note: this function is not supported in ABZ Control).

The remote controller battery status is displayed in the Android menu (by swiping down from the top of the screen).

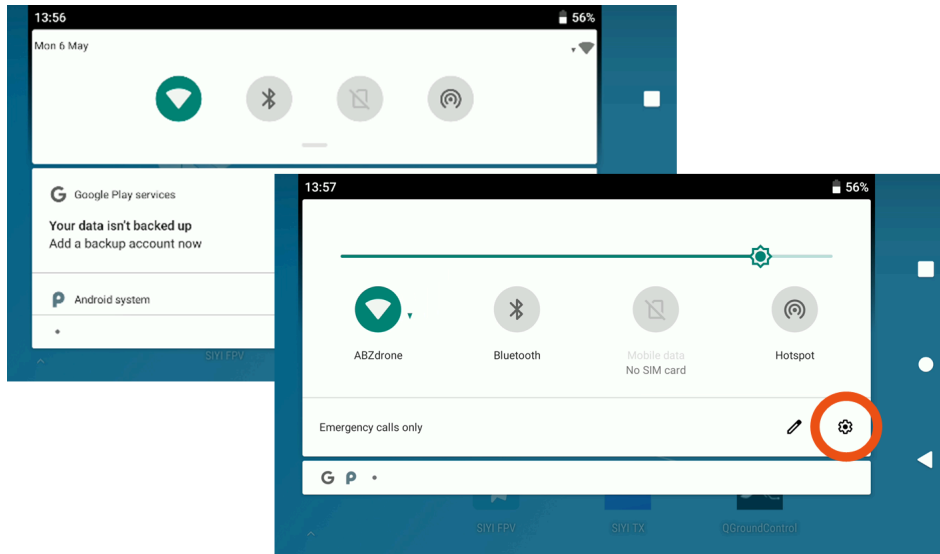

Set the **display brightness** and **sound volume** always according to environmental conditions (light conditions and noise level)! Setting the display brightness and sound volume is always accessible (even when operating the ABZ Control software) from the basic Android menu, swiping down from the top of the touch screen once, where the general Android quick menu appears.

Swiping down from the top of the touch screen once more, the slider for the display brightness setting appears:

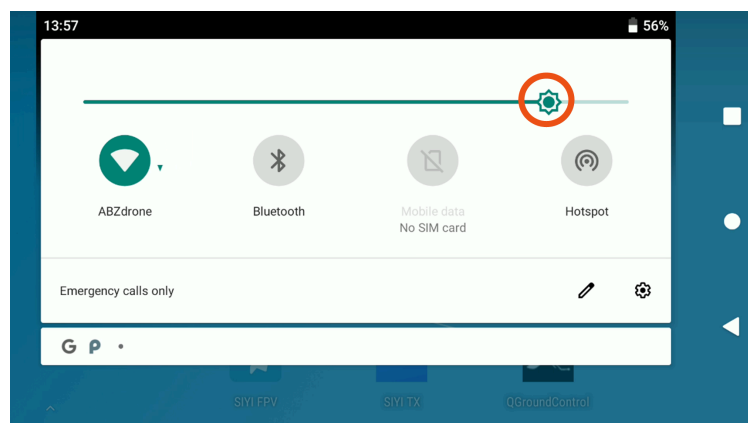

Click on **Settings (gear icon)** then scroll down to the **Sound** menu and tap on it to show the sliders for volume control functions.

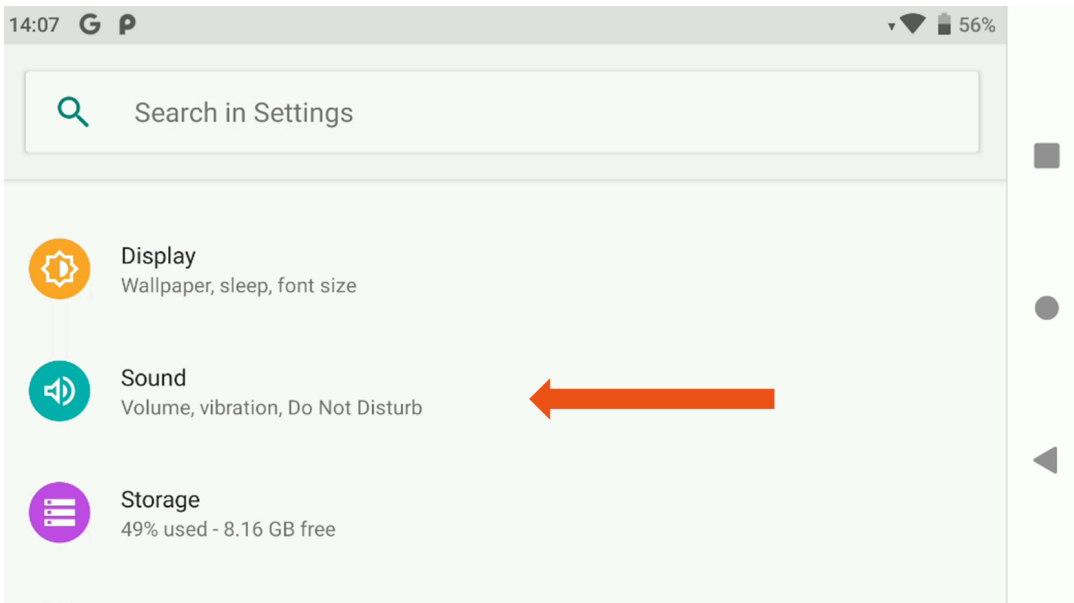

**Media volume** controls the ABZ Control application's alerts and information volumes. We highly recommend this always be set to the maximum volume.



## Network settings

To ensure the proper functioning of the ABZ Control application, the Ethernet connection must always be turned on. This setting is available under *Android Settings > Network & Internet*.

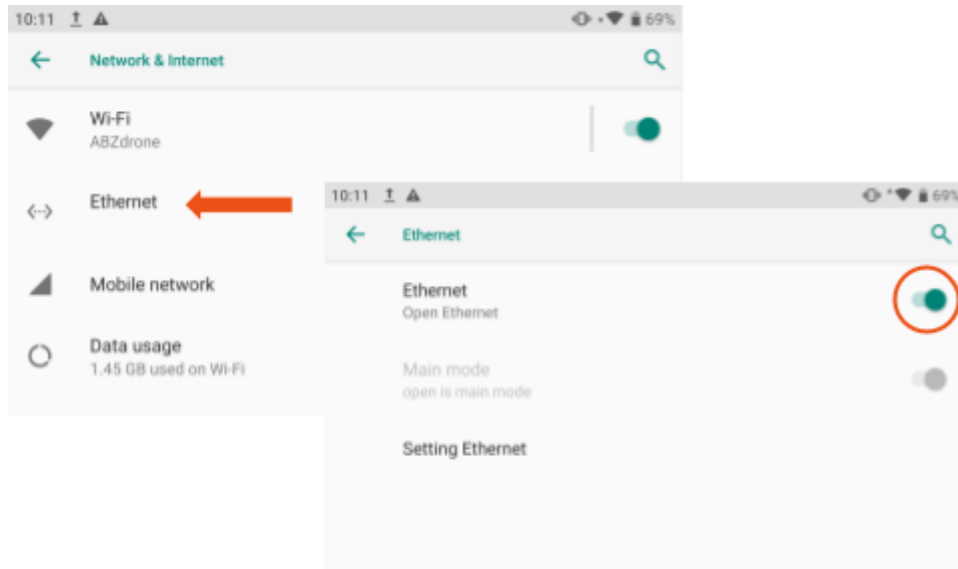

## Internet connection

The remote controller can access the internet via Wi-Fi or Bluetooth connection, e.g. shared from a router, mobile phone, tablet, or laptop.

These options are available in the Android's Settings menu (by swiping down from top), by long pressing the Wi-Fi or Bluetooth icon, or by tapping the gear icon.

In the submenu, the function can be switched on/off and the available devices can be connected. Wi-Fi only works on 2.4GHz networks. If the controller does not recognize the Wi-Fi from your mobile device, using Bluetooth connection for internet access is recommended.

## To set up the Bluetooth connection for internet access:

1. Turn off Wi-Fi on the controller.
2. Turn on Bluetooth hotspot / internet sharing on your mobile device.
3. Turn on Bluetooth on the controller and pair the two devices.
4. If your device is connected to the controller, you need to set up the internet connection.
5. Tap on the gear icon next to the device name, then turn on the Internet access.

## ABZ Control Software Overview

The C10 is compatible only with the controllers provided by ABZ Innovation with specialized ABZ Control software. Other devices or applications are not compatible for controlling the drone and, therefore, are prohibited from use with the drone.

No software update is needed before and during operating the drone; future updates are only optional. Any future software updates will not affect the control and flight functions. Software update procedures are explained and guided in the documentation of the update package. All information and files are available at: [abzinnovation.com/updates](http://abzinnovation.com/updates). Please check this website if you are looking for software or firmware update options.

**Start the ABZ Control flight control and planning application by clicking on its icon on the home screen.**

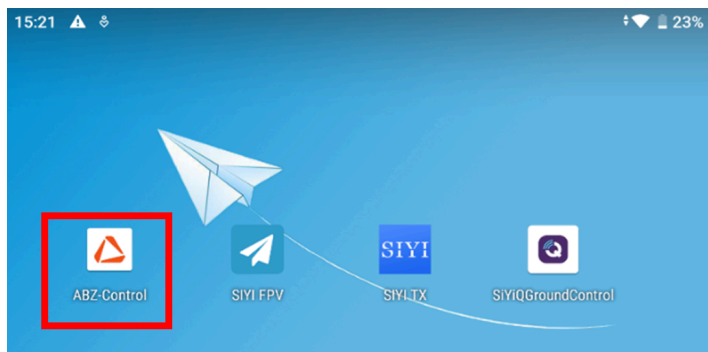

After starting the ABZ Control application, you will receive a pop-up window with the message: Allow ABZ Control to access USB to UART Controller. Click on OK.

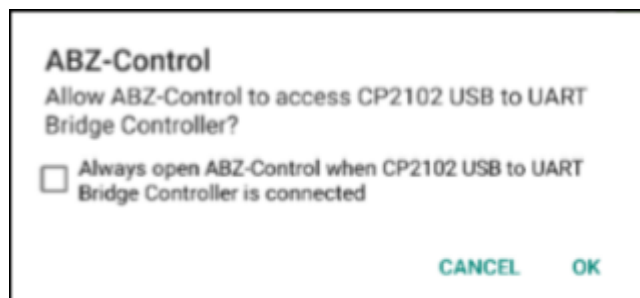

After launching the application, the following screen will be displayed: In the top menu bar, you will see the **Flight view and the Settings** icons.



After turning on and connecting the drone, you will find additional status icons at the top: vehicle messages, GPS status, Drone Battery status, and Payload status. On the left side of the top bar, a red no-entry sign indicates that the drone is still preparing its systems for the flight. If the icon changes to a green check mark, the drone is ready and can be armed.



The drone battery icon serves only as an indicator and shows an approximate value. During the flight, the pilot must monitor the battery voltage, which should always be above 43.5 V, even when flying with the Maximum Take-off Mass (MTOM). When the battery voltage level drops under 43.5 V, start returning and landing the drone.

The state of the drone battery should also be monitored before the flight using the charging indicator LEDs on the battery. We recommend starting the flight with a minimum of 80% battery charge.



The real-time altitude of the drone, based on either barometer or GNSS sensors, is displayed in the bottom-right corner of the screen. For more information regarding the [altitude control methods](#), see page 35.

In the bottom-left corner of the screen, the current status of the Automatic Distance Control System is displayed. This system can have three states: Disabled, Off, and On.

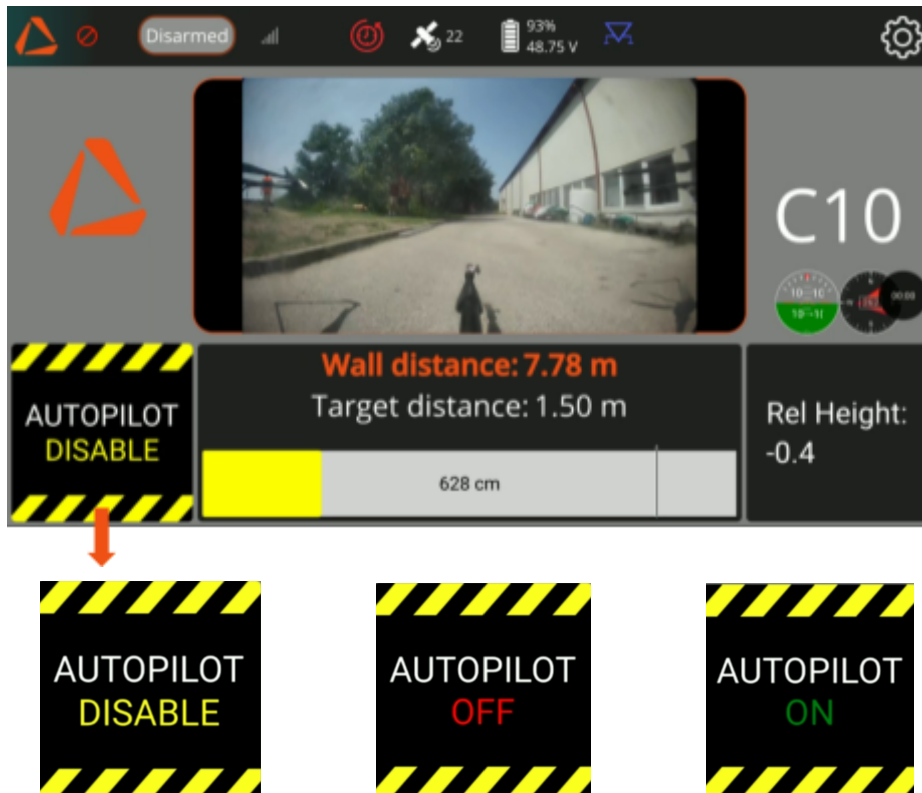

For more information about the [Automatic Distance Control System](#), see page 38.

To support the pilot, the live camera view is shown in the center of the screen for better visibility during operation.

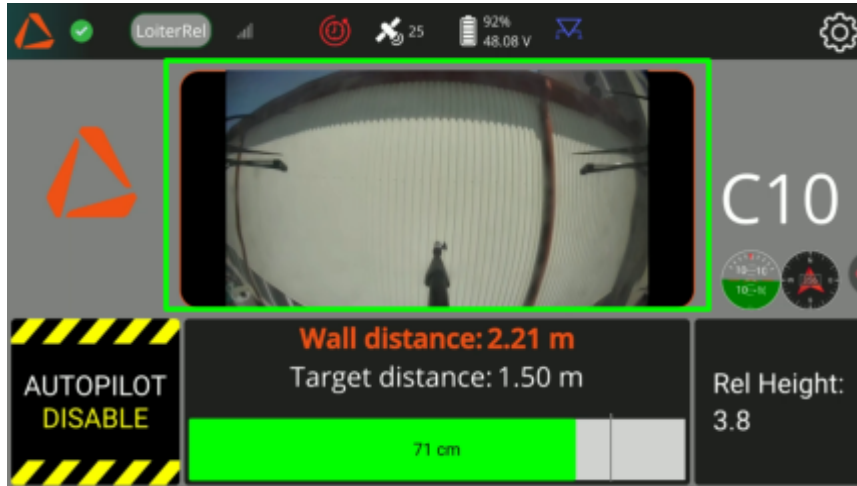

The distance from the wall can be monitored during flight using the display bar at the bottom of the screen.

A color bar at the bottom of the screen visualizes the distance of the drone from the wall.

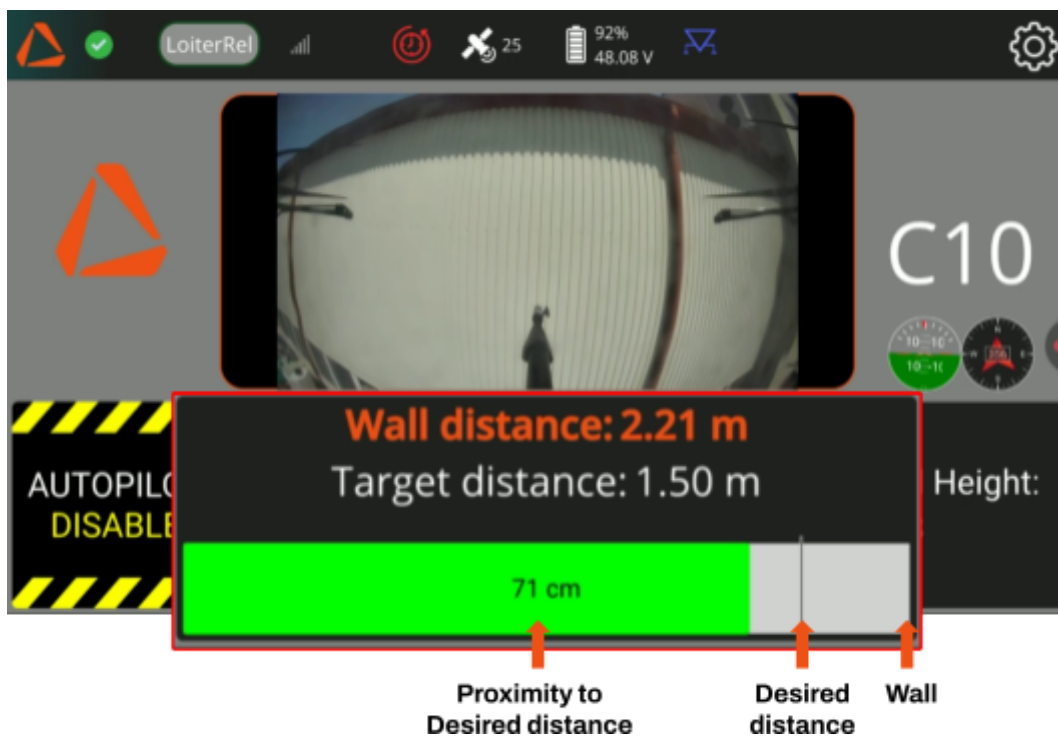

- The right edge of the bar represents the wall surface. The thin strip in the middle indicates the desired distance (Target distance).
- The value displayed as "**Wall distance**" shows the drone's current distance from the wall.
- The value displayed **inside the bar** shows the amount of deviation from the desired distance (Target distance).
- The bar's color changes to indicate the drone's proximity to the desired distance:
  - **Red:** The drone is far from the desired distance or has exceeded it.
  - **Yellow:** The drone is getting closer, within 2 meters of the desired distance.
  - **Green:** The drone is within 1 meter of the desired distance. The **automatic distance control** function can now be activated.

## Settings

In the **Settings** menu, you can adjust user interface options (such as language or units of measurement), configure drone operation-related behavior, and set up distance control systems under the **Payload** option. To access **Settings**, tap the gear icon in the top-right corner of the screen.

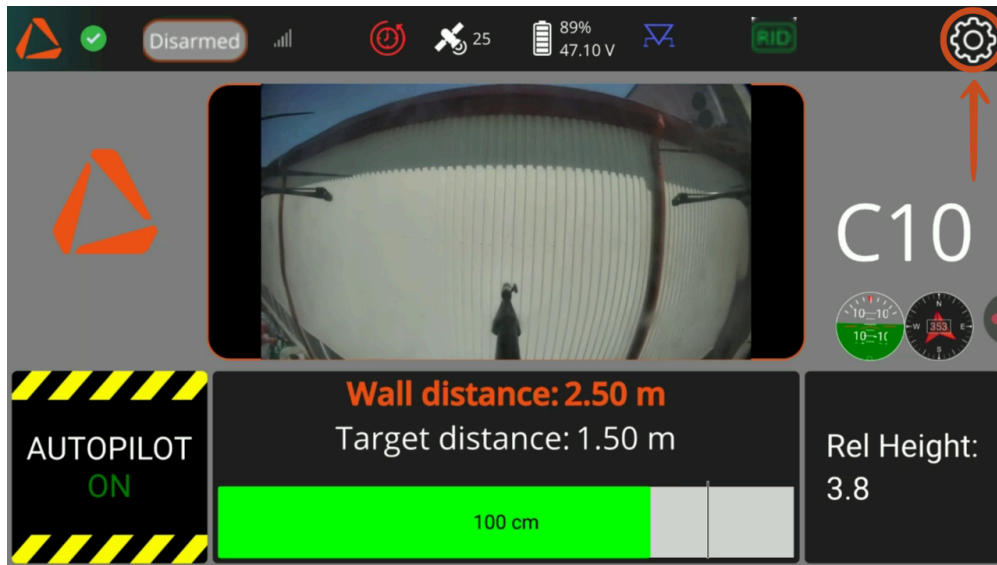

In the **General** menu, you can configure various settings, including the default units used for measurements in the ABZ Control interface

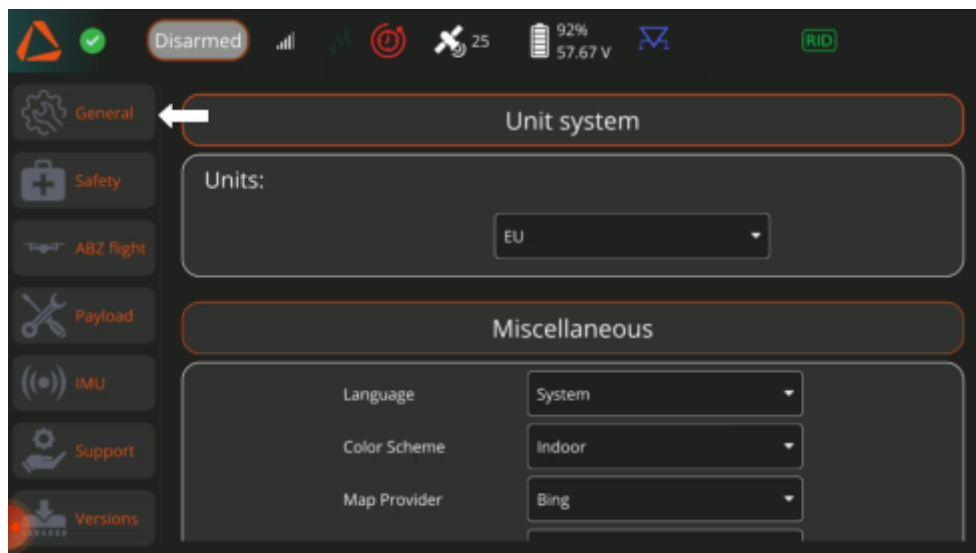

Under the **Camera View** section, you can view the camera type used by ABZ Control. The default setting is FPV.

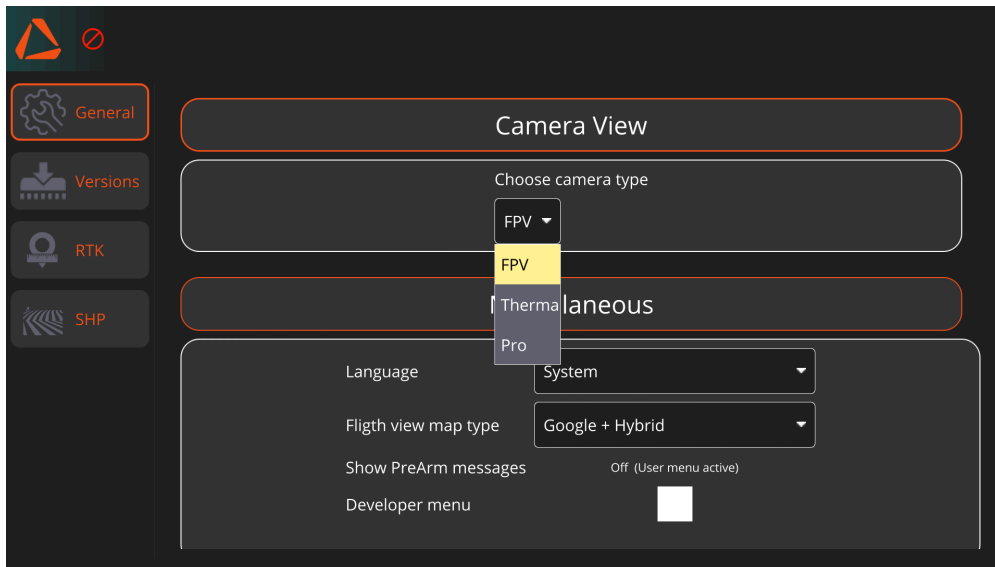

The current software version of your drone is displayed at the bottom of this page. If you contact our Support Center with an inquiry regarding your drone, you will be required to provide this information. The same details are also accessible via the *Settings > Versions* menu.

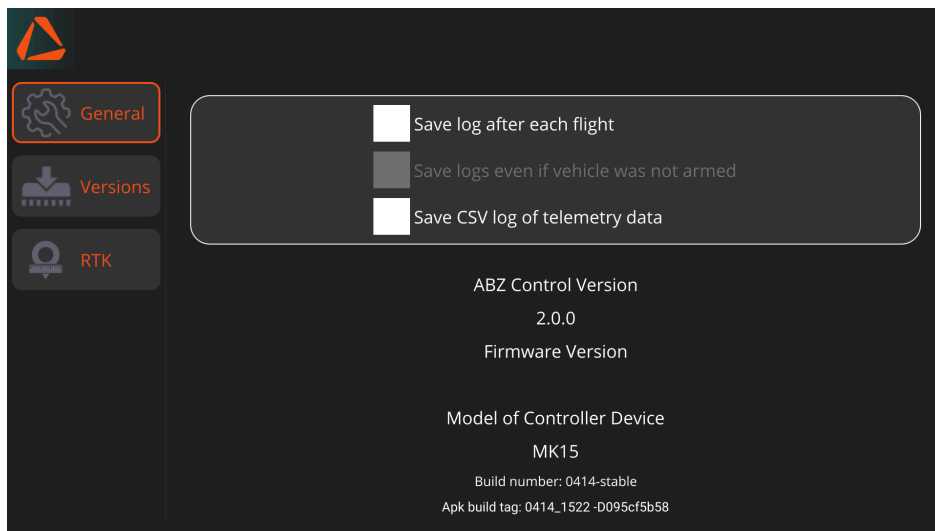

## Safety – Setting up FailSafe

When using a UAS, unexpected events may occur that require intervention. The FailSafe settings are required by law, primarily to prevent personal injury and property damage.

In the case of a tethered drone, most safety settings are predetermined by law and cannot be modified. These requirements have been implemented in the C10 system. Under *Settings > Safety*, you can configure the Geofence functions: you can set virtual boundaries that the drone will not fly beyond.

- **GeoCage:** **Circle GeoFence** means the drone will stop if it reaches the specified radius from the takeoff position. **Altitude GeoFence** means the drone will not fly above the set altitude relative to the takeoff position. The C10 drone is designed never to exceed a height of 120 meters.

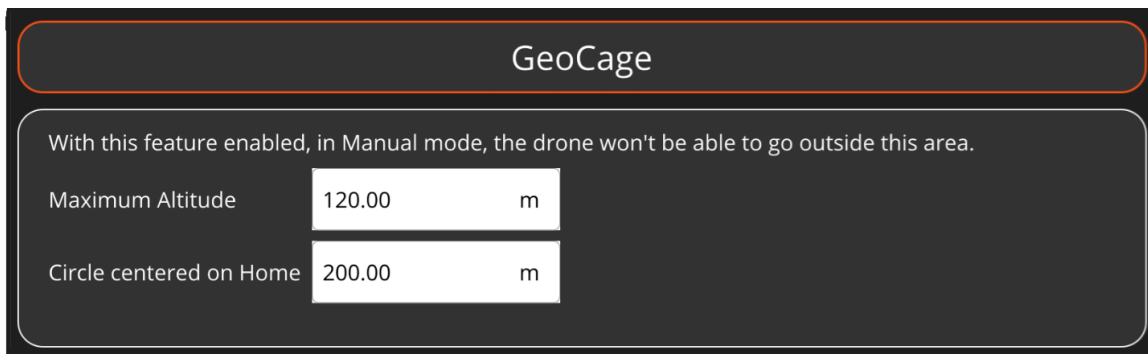

## Abz Flight

In the **ABZ Flight** menu, you can set the primary height source for the Relative altitude hold method.

In Relative Settings, you can specify the primary height source for the drone. **This setting can only be changed when the drone is grounded and disarmed.** Only use GNSS if flying with an RTK source (e.g., Emlid base station). To learn more about the different altitude control methods, see [“Altitude control”](#) (page 55).

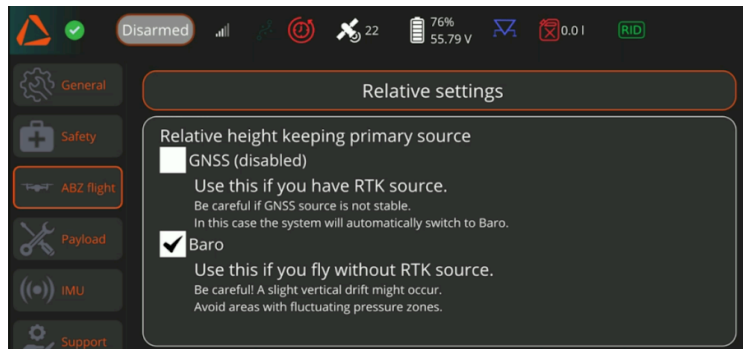

Under the **Advanced** section, you can enable flight mode settings that are initially disabled on the Remote Controller:

- **AltHold Mode:** Allows you to assign Alt Hold to the **C button** and the **virtual Flight Mode function button** (in ABZ Control).
- (Please disregard the option for turning on the altitude control method switch (3-stage switch), as it is not applicable to your drone type.)

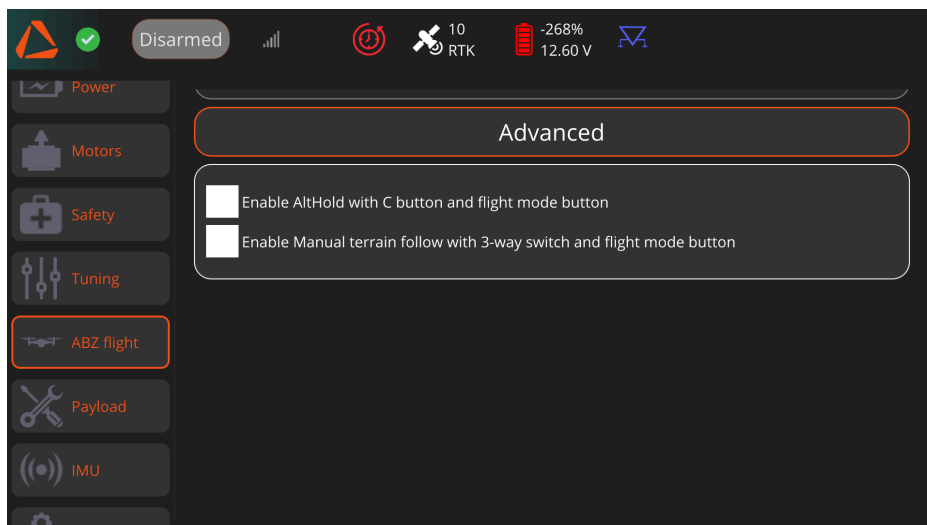

## RTK configuration

In the **RTK menu**, you can connect to a server that provides RTK correction to your drone, or connect to your **Emlid base station via LoRa radio or NTRIP**.

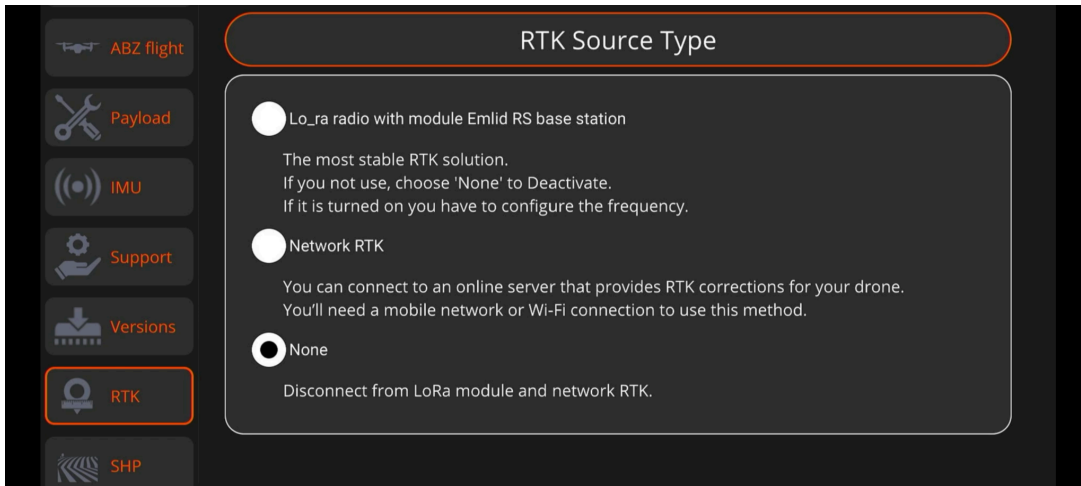

- If using an **Emlid RS base station with LoRa**, make sure it is configured to **Output: LoRa**, and that the frequency matches the Base output value specified in the Emlid flow app. You can also connect to an **Emlid RS base station via NTRIP** using the **Network RTK** option. For the required credentials, refer to the **Emlid Flow app**.
- Under **Network RTK**, you can connect to the nearest **Continuously Operating Reference Station (CORS)** via an **NTRIP Caster**. To use this option, you will need an internet connection using your mobile device as a hotspot.

To connect and receive corrections, enter the credentials provided by your NTRIP service provider. For best results, always select the station nearest to your operating location.

**If you choose to fly with an RTK source, the system will only allow you to arm the drone if the correction data is accurate enough to ensure proper drone positioning.**

## Software versions and Update

You can check the current drone firmware and ABZ Control software versions under **Settings > Versions**. If you contact our Support Center with an inquiry regarding your drone, you will be required to provide this information.

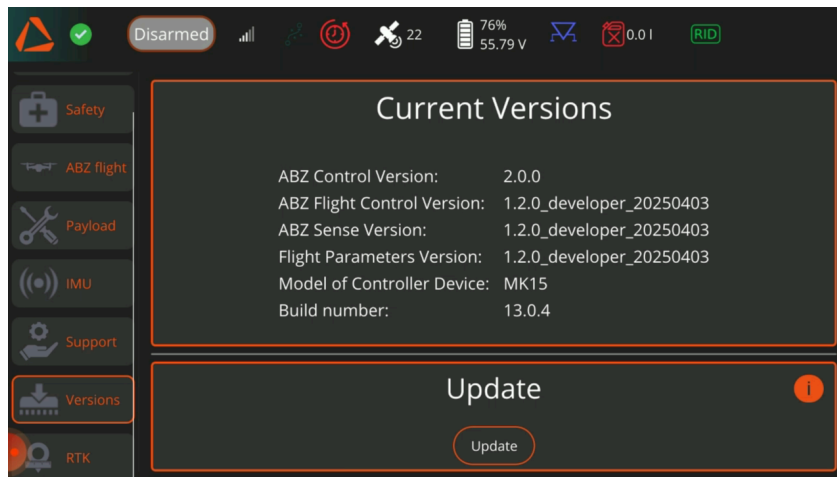

ABZ Innovation communicates all new software releases via email. Only perform updates when instructed to do so by ABZ Innovation.

## Payloads

In *Settings > Payload*, you can set the **Disarmed distance (Target distance)** and the **emergency push distance** for the Automatic Distance Control System. The desired distance value can be set between 0.9 –10 meters, the emergency push can be set between 0.1 –9.7 meters. The value of Emergency Push cannot be set higher than the Desired Distance (Target distance). The distance between the two values is always at least 0.3 meters.

**The distances will be measured from the radar, not from the tip of the lance!**

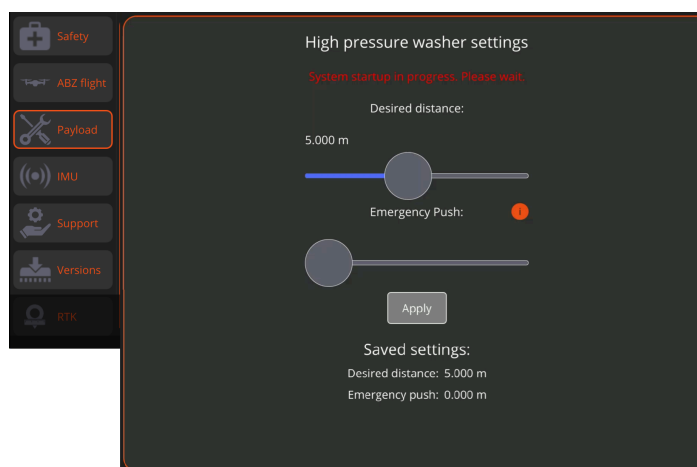

(For further information about the [Automatic Distance Control System](#), see page 38).

## Controlling the drone

It is only permitted to operate the drone in full compliance with this entire operator's manual and specifically the checklists.

## Default control (mode 2)

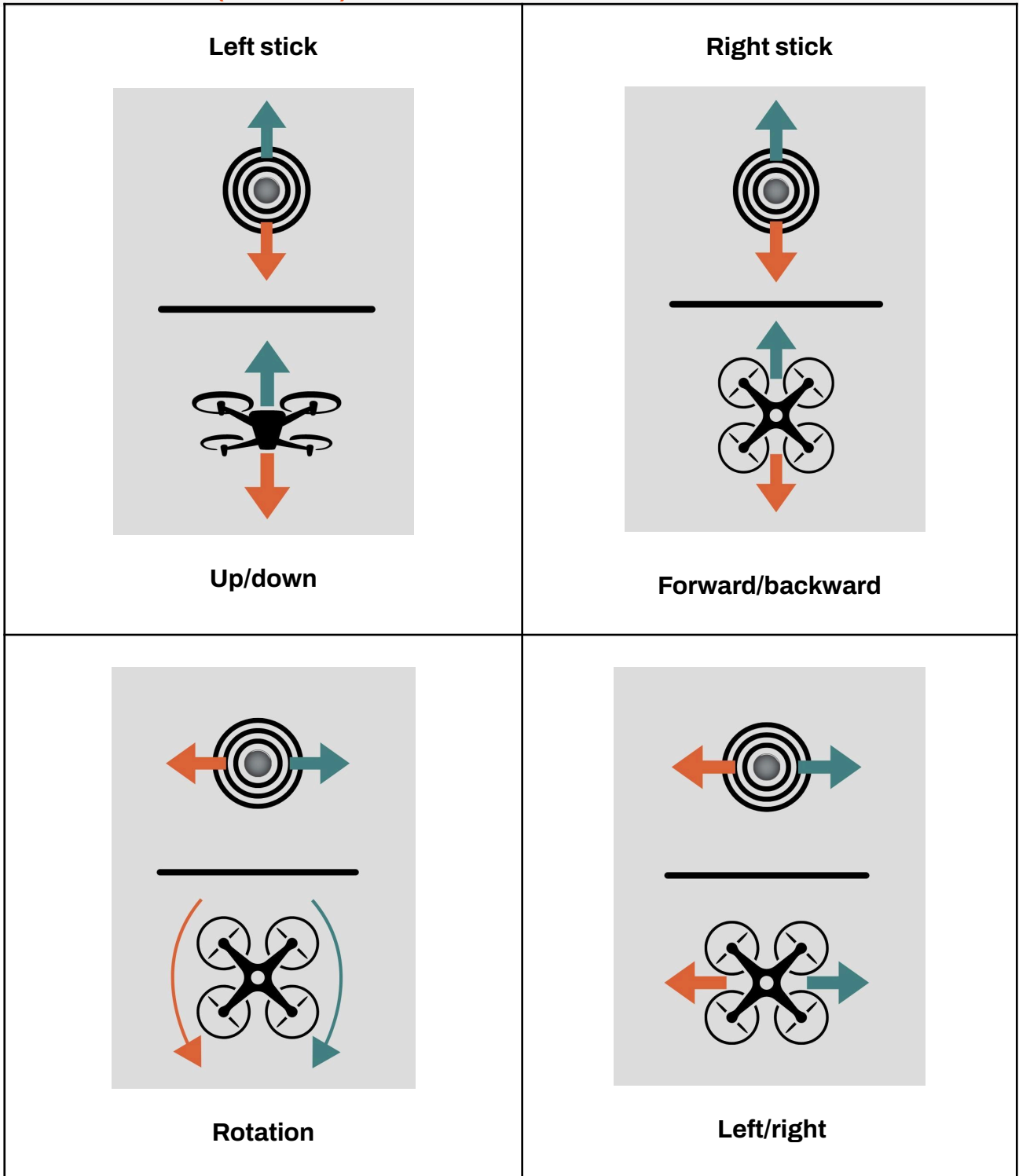

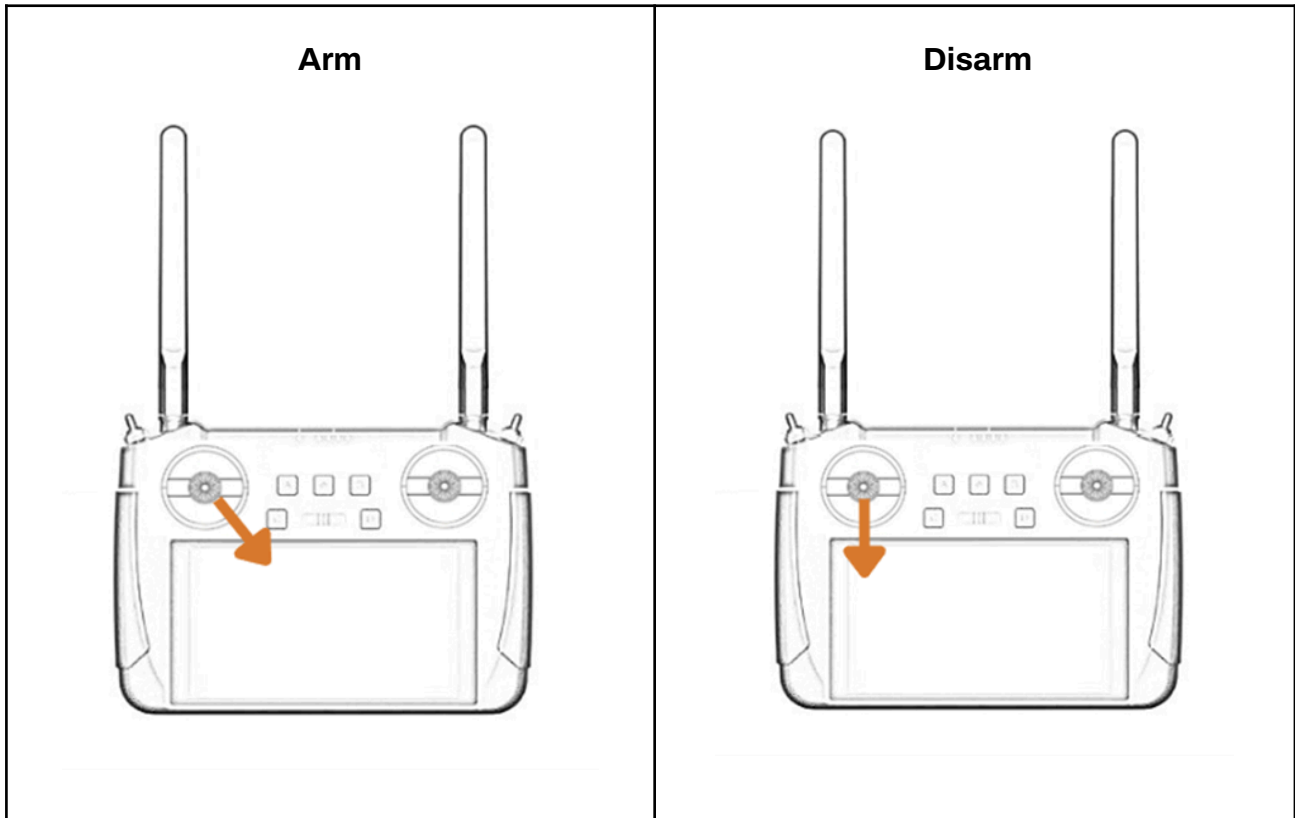

### Manual flight commands:

**Emergency stop:** In case of emergency, push the **C button** and **D button**. The motors will stop immediately, and the drone will crash into the ground.

The drone's pitch and roll angles, turning radius, climb, and descend speeds are limited by firmware in order to ensure safe flight. The pilot can safely fly the drone within all possible pilot inputs, no extra limitations are needed to implement manually.

- **Takeoff:** Switch to "Armed" mode by pushing the left control stick fully to the **down-right position** until "Armed" is shown on display, then release.
- After the motors are started, fly the drone manually by controlling it with the left and right sticks in Mode 2 by default and take off to a safe height (at least 2m).
- **Land: Manually** control the descent speed and **slow it down** before reaching ground.
- After landing, switch to „**Disarmed**“ mode by pushing the **left control** stick fully to the down position until „Disarmed“ is shown on the display and the motors are completely stopped, then release.

Make sure to release the stick immediately after arming or disarming, once the RC notifies you of the status change. Otherwise, the system may interpret your action as accidental and revert to the previously selected mode.

When you arm or disarm the drone, a large orange text appears on the screen, notifying you of the drone's status change:

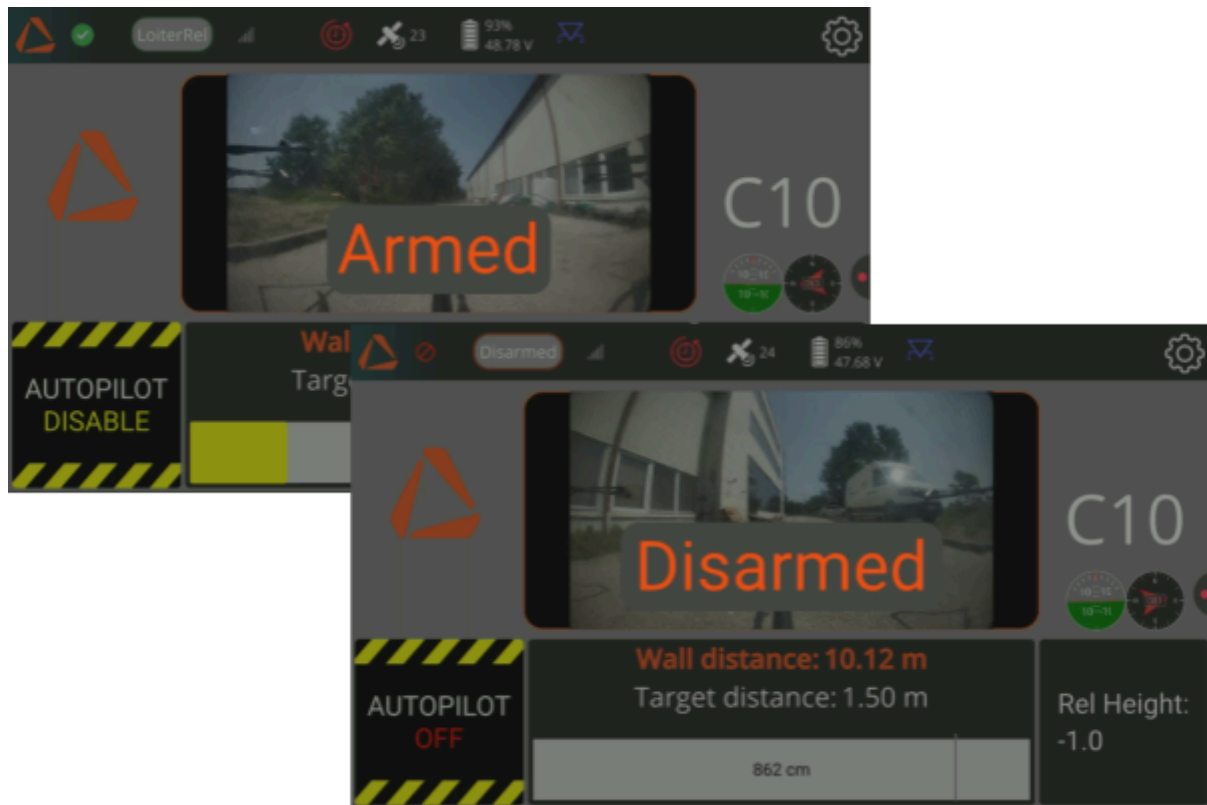

## Altitude control

By default, Relative Altitude Hold mode uses barometric measurements as the primary height source. The drone's altitude is maintained relative to the takeoff point. The pilot must be aware of altitude variations caused by atmospheric and weather changes.

If you are flying with an **Emlid base station or Network RTK using correction data**, the drone can rely on GPS information as Primary Height source.

You can enable this mode in **Settings > ABZ Flight** when the drone is grounded and disarmed.

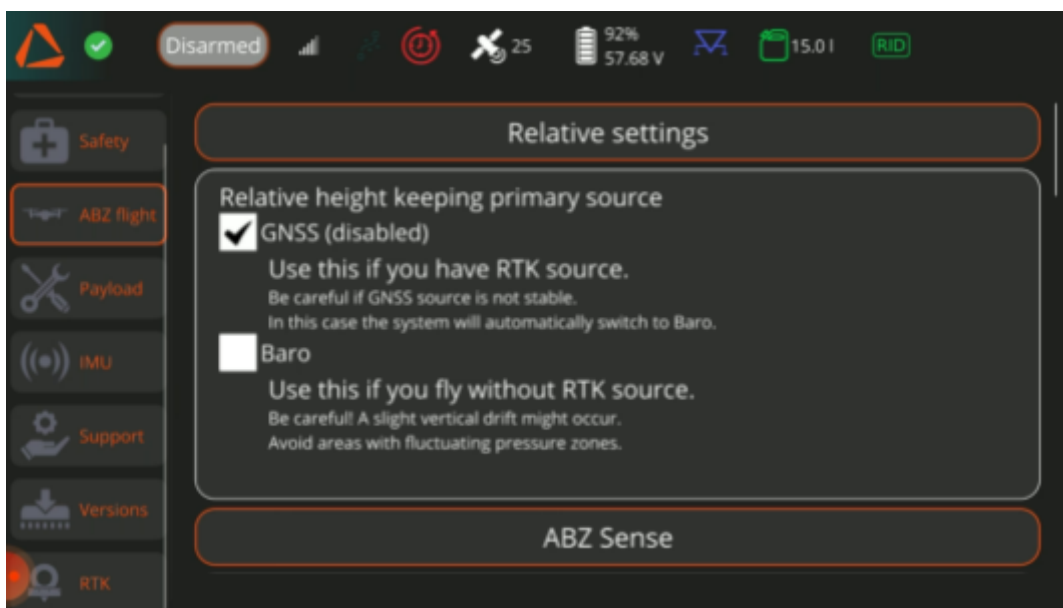

## Cleaning System installation

Please follow this manual to safely and correctly install and remove the lance on your ABZ Innovation C10 cleaning drone.

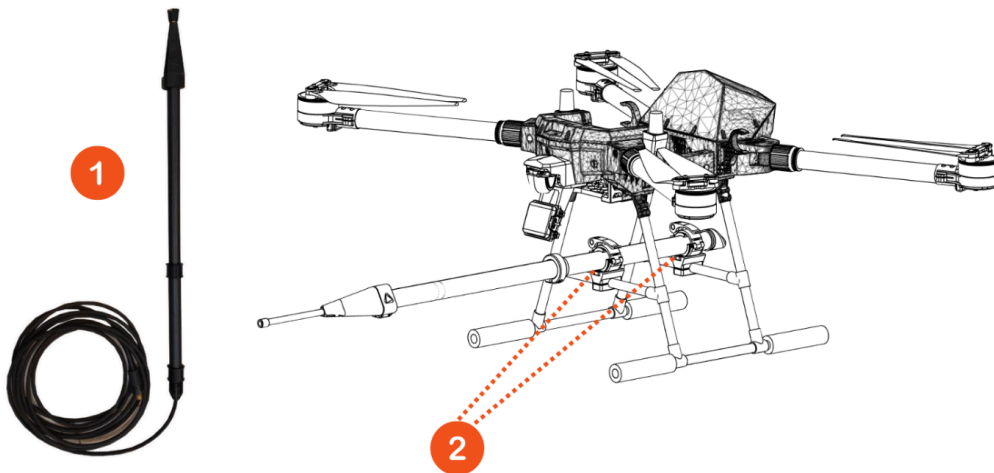

1. Cleaning lance

2. Mounting clamps

## Assembly Instructions

1. Open the mounting clamp using the quick-release lever to prepare the drone for assembly.

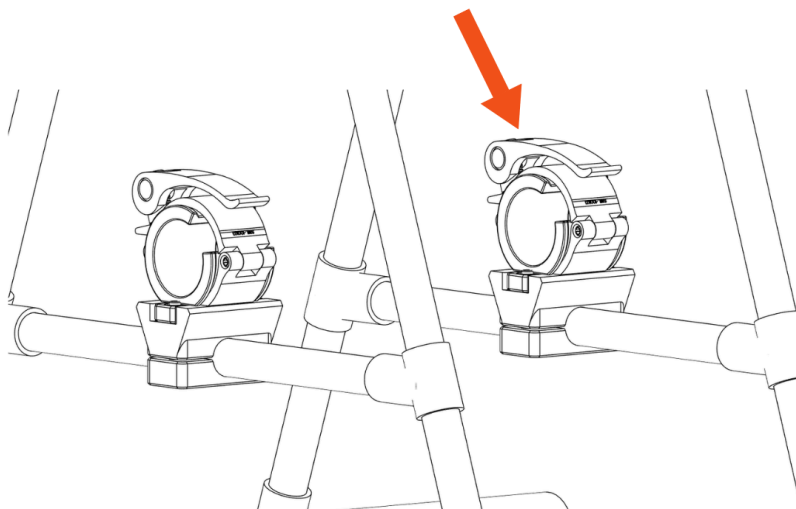

2. Carefully insert the lance into the mounting clamp, starting from the rear.
3. Close the rear mounting clamp using the quick-release lever, but do not tighten it fully. Leave it slightly loose to allow for manual adjustment of the lance if necessary.

You can adjust the tightness of the mounting clamp by turning the open quick-release lever.

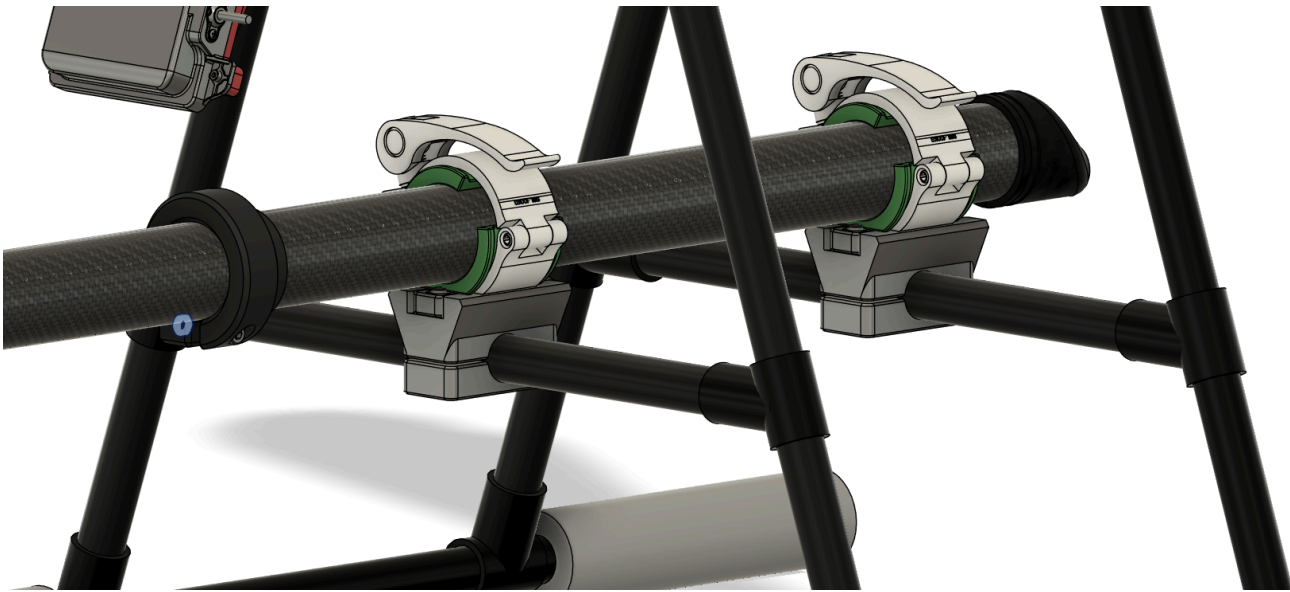

**IMPORTANT:** Adjust the lance position only within the range defined by the front ring and the rear bracket. **Improper use will result in the drone becoming uncontrollable!**

Using the tilting nozzle holder in the extended position is prohibited. If using the tilting nozzle holder, ensure that the limiter ring on the lance touches the outer side of the front quick-release clamp.

5. Secure the Mounting clamps firmly.

## Lance Removal

1. Unlock both quick-release levers to prepare for the removal process.
2. Carefully remove the lance from the clamps.

## Changing the nozzle holder

Your C10 drone comes with two types of nozzle holders (straight and tilting). Before changing them, ensure that the screw on the downward-facing side of the plastic housing is properly tightened to 3.2 Nm using a 5mm hex head tool. When securing the nozzle holder, do not apply excessive force—tighten it by hand only.

## Adjusting the metal extension tube

If you are using the C10 with the standard nozzle holder and require it for your operation, you can adjust the length of the metal extension tube enclosed in the lance to extend below the lances head. To do so, loosen the screw on the downward-facing side of the plastic housing.

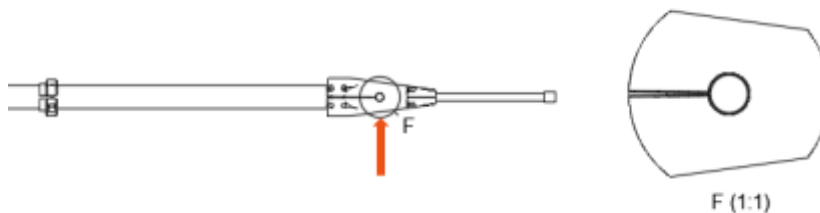

**IMPORTANT:** Using the tilting nozzle holder is prohibited in extended position. Please use the tilting nozzle only in fully retracted position of the metal extension tube! Also please make sure that the limiter ring on the lance touches the outer side of the front quick release clamp.

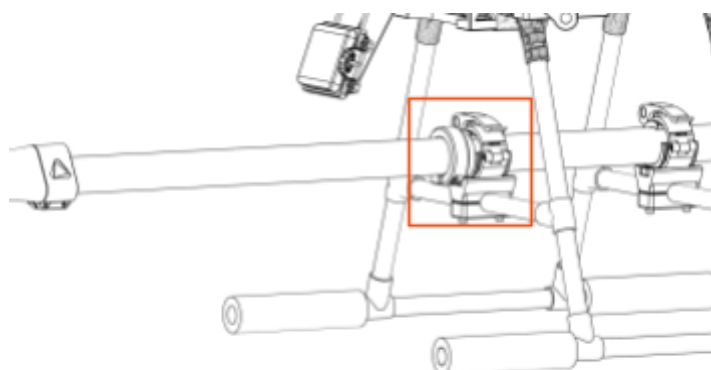
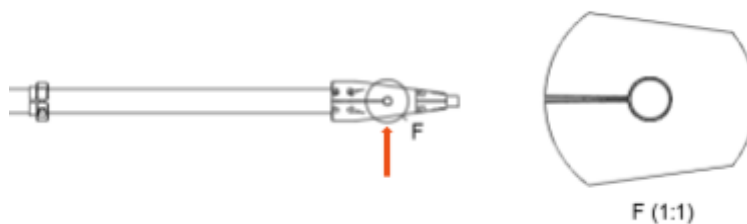

## Automatic Distance Control System (Radar-Based)

The **C10 drone is equipped with an automatic distance control system** that uses radar technology to support safe and efficient washing operations.

The automatic distance control system is a pilot-assist feature designed to improve operational safety and precision. By continuously measuring the distance between the drone and the surface being cleaned, the system helps maintain a consistent working distance and prevents dangerous proximity.

### The radar:

The front-mounted radar on the drone measures the distance to the surface being cleaned.

**Note that this measurement is taken from the radar's position—not from the tip of the lance.**

The Radar, mounted on the front of the drone, can determine the distance to the surface with an accuracy of 2-6cm, from 0.5m to 50m. It has a horizontal viewing angle of 43° and a vertical viewing angle of 30°.

### Important:

**This system is not a substitute for manual control. It is intended as a support tool and does NOT autonomously fly or manage the drone.**

**The pilot remains fully responsible for safe and accurate operation at all times.**

The desired distance can be set in the **ABZ Control > Settings > Payload** with the value of the **High pressure washer settings**.

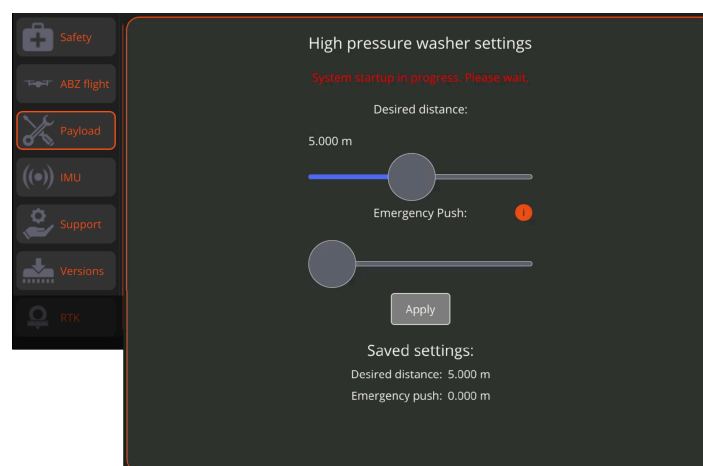

**The distance will be measured from the radar, not from the tip of the lance!**

The Automatic Distance Control System has three states: Disabled, Off, and On. After restarting the drone, the system defaults to the Disabled state. To enable it, press **Button D**.

**Never arm the drone with the Automatic Distance Control System activated (status: ON).  
Before landing, always turn off the Automatic Distance Control System!**

## Key Automatic Distance Control System Functions:

### 1. Distance Maintenance:

Keeps the drone at a constant distance from the target surface during cleaning, ensuring optimal washing performance. The **Desired Distance** (Target distance) from the wall can be set between 0.9 and 10 meters under **Settings > Payload**.

### 2. Emergency Response & Error Handling:

- Automatically moves the drone away if it gets too close to the surface due to sudden external factors (e.g., gusts of wind). You can set the Emergency Push distance under **Settings > Payload**. The Emergency Push distance can be adjusted between 0.1 and 9.7 meters, but it cannot exceed the Desired Distance. The distance between the two values is always at least 0.3 meters.

If the drone approaches an object while the Automatic Distance Control System is active, it will execute a decisive distancing maneuver for safety and then wait for pilot intervention to reactivate the system.

- May detect and respond to potential pilot errors to reduce the risk of collisions.

If an anomaly is detected—caused by a hardware/software interruption (e.g. damaged radar or faculty part) or Operational interruption (e.g. measuring past the edge of a wall) —the system will return to the Disabled state.

During flight, a color bar at the bottom of the screen will help you find the correct starting operational distance from the wall.

The bar itself provides a quick visual guide. The right edge represents the wall, and a thin strip in the middle marks your desired distance (Target distance).

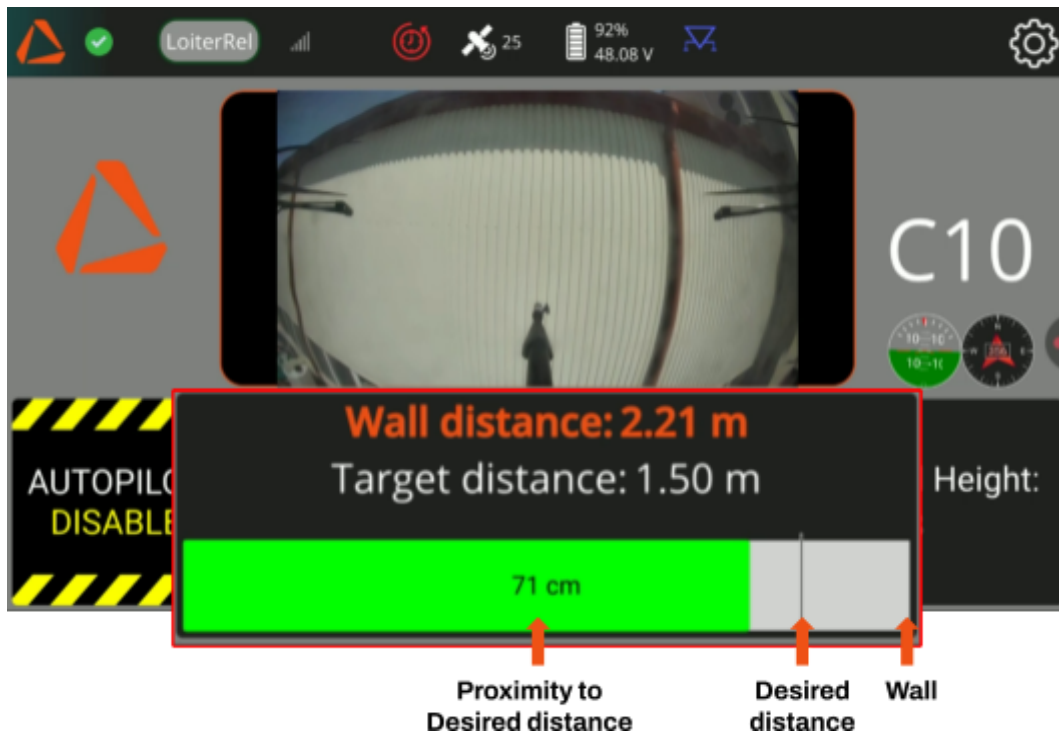

As you pilot the drone, the bar will change color to indicate your position relative to this target.

- **Red:** The drone is far from the desired distance or has exceeded it.
- **Yellow:** The drone is getting closer, within 2 meters of the desired distance.
- **Green:** The drone is within 1 meter of the desired distance.

Once the bar turns Green, the drone is within 1 meter of the desired distance, which is the correct position to begin work. At this stage, you can safely activate the Automatic Distance Control function to have the drone hold its distance from the surface automatically.

If enabled (with the **status showing 'OFF'** in the top-right corner of the screen), the pilot can activate the Automatic Distance Control by setting the **top-right 3-position switch** to its middle or lowest position. The **system's status will then change to 'ON'**. In this mode, forward and backward stick movement is disabled for the pilot.



## Challenges Posed by Irregular Surfaces

The drone's onboard radar and positioning systems rely on consistent, reflective surfaces to accurately determine distance and orientation. If the target surface is irregular—such as leaky, broken, or incomplete walls—it may scatter or absorb radio waves, resulting in poor signal return and degraded positional accuracy.

### Key Issues:

- **Low Reflectivity:** Surfaces that do not reflect radar signals effectively (e.g., porous materials, holes, gaps) reduce navigation precision.
- **Signal Noise:** Structural irregularities may introduce interference or false readings.
- **Weakened Radar Stability:** Fragmented or uneven surfaces compromise the reliability of distance measurement.

If radar-based control is unreliable due to surface inconsistency, turn off the automatic distance control, and switch to manual flight mode to continue the operation.

**Important: Manual operation should only be attempted by experienced pilots who are familiar with proximity-based flight controls and obstacle avoidance.**

## Emergency Response & Error Handling

If the drone detects abnormal operation—caused by a software error, hardware failure, or operational mistake—it will immediately alert the pilot. In the event that an internal system component fails to function as expected, the automatic distance control will be deactivated until the issue is resolved. Possible causes of such failures include:

- A damaged radar sensor
- A faulty internal component

An operational interruption may occur due to an emergency caused by **pilot error** or a **sudden environmental change**. Depending on the severity and urgency of the failure, the drone may either perform an autonomous motion override or return full control to the remote pilot.

- **Drone approaching the surface/an obstacle at a critical distance**  
*Interruption:* If the drone detects an obstacle (such as a protruding surface element) within the defined Emergency Push distance (defined under Settings > Payload), it will automatically push backwards at maximum speed until it reaches 2 meters, then disable Automatic Distance Control and switch to manual (Loiter) mode.
- **Radar drift causes false distance readings when near the edge of the wall surface**  
*Interruption:* The automatic distance control will shut off.

**IMPORTANT:** Strong and unpredictable wind gusts or turbulence may occur near building edges. These conditions can cause abrupt or unstable drone movements that must be carefully managed by the pilot.

## Washing system operation

Operating the C10 drone with the high-pressure washing system is a two-person job requiring a Pilot and a Helper/Supervisor. Seamless coordination between both team members is essential for ensuring a safe and efficient cleaning process from start to finish.

### Roles and Responsibilities

**Pilot:** is responsible for controlling the drone's flight and uses standardized hand signals to communicate with the Helper or Supervisor.

**Helper/Supervisor:** operates the high-pressure washing system, turning it ON and OFF as needed. They also manage and adjust the high-pressure hose and observe the environment to support safe drone operation.

## Operational procedure

For optimal positioning of the drone, **mark a 6-8 meter wide section of the wall to be washed and position the hose system in the middle of that section** on the ground. **Keep the drone within a +/- 3-4 meter horizontal range from the ground system's position** as you move up and down the washing area.

Once a section is complete, power down the drone, then reposition both the drone and the hose system to the center of the next 6-8 meter section before resuming operation.

### 1. Preparation

- Before any flight, conduct all required [pre-operation safety checks](#) (see page 45) to ensure the operational readiness of the drone, equipment, and the safe operational zone and environment.
- Clearly assign the roles of Pilot and Helper/Supervisor and review the standard hand signals for communication.

## 2. Hose Setup

It is critical to position the high-pressure hose strategically to ensure free water flow and give the drone maximum maneuverability.

The high-pressure hose must be free of lumps, kinks, and overlaps that could restrict water flow or snag during flight.

**Before starting the system, vent all hoses to purge any trapped air.**

**Important: To allow for unrestricted water flow and optimal maneuverability, try to position the high-pressure hose in a pattern that avoids sharp bends and allows it to move freely.**

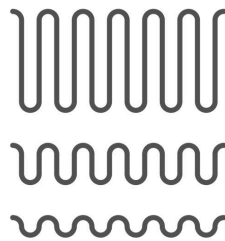

The hose should be placed at the base of the surface to be washed (maximum width: 6–8 meters), preferably centered, to minimize lateral pull on the drone.

## 3. Flight and Cleaning Operations

**Before takeoff, ensure that the automatic distance control is set to Disabled/OFF status.**

- During ascent, the Helper/Supervisor should stand by, carefully monitoring the high-pressure hose to ensure it feeds out smoothly without interfering with the drone.

**When moving the hose with a strong force, move the drone forwards/backwards only. In case of sideways pulling, the counter-force of the hose will force the drone to rotate, which may pose a safety hazard.**

- Once the drone reaches approximately 5 meters from the surface, the pilot can give the designated hand signal, and the helper or supervisor should start the high-pressure washing system.
- With the drone in a perpendicular position, carefully approach the target surface until you are 1 meter beyond the predefined desired distance (target distance).
- Turn on the Automatic Distance Control System.
- You can start the operation.

## 4. Concluding the Operation

1. To begin the landing process, automatic distance control must be switched off.
2. Fly to a safe distance from the wall before proceeding to switch off the washing system.

**After switching off the Washing System, the drone may slide forward 0.5 to 1 meter due to the sudden loss of counterforce.**

3. The Helper/Supervisor can turn off the high-pressure system.
4. During landing, the Helper/Supervisor must ensure the high-pressure hose is safely arranged on the ground to prevent any obstruction or entanglement during the drone's descent and landing.

**Below a height of 20 cm, the drone should only be moved downward—not forward, backward, or sideways—as any lateral movement may pose a safety risk.**

## Flight

If needed, check Failsafe settings and adjust them according to the actual flight task and surroundings.

Set the display brightness in accordance with the lighting conditions. Every data on the display should be readable even in direct sunlight. Turn off unnecessary nearby Wi-Fi and radio equipment to minimize interference.

If all the necessary conditions for the flight are ensured, you can then enter the Flight view to start the flight, switching to "Armed" mode.

**If any flight system errors occur during the flight, the controller shows a pop-up message with information about abnormalities.**

In emergency situations, the pilot must operate the drone manually in the safest available manner, specifically taking care of personal and property security. The pilot must fly the drone away from potential risks, applying careful, slow stick inputs and flight speeds, find a safe area, and land the drone with a slow descent rate.

**In case of a „Potential thrust loss” message, the pilot must land the drone as soon as possible, operating it with slow and smooth motion.**

## Flight Protocol and Checklists

### Before flight, tasks and inspections

- Determine the flight location.
- The task to be performed is properly analyzed.
- Permits applied for and obtained.
- Visual inspection of the area performed
- Inspect the surface to be cleaned: If the wall surface is leaky, broken, or incomplete, radar signal stability may be reduced.
- The operational area is secured
- The obstacles in the built environment identified
- Neighbours and other limiting factors identified
- Tools and accessories needed for the work are prepared.
- The pilot is fit and ready to work.  
(IMSAFE: Illness, Medication, Stress, Alcohol, Fatigue, Eating)
- Set the remote controller's sound volume according to the ambient noise.
- Set the remote controller's display brightness according to ambient light conditions.

### Pre-arming tasks and inspections

- The meteorological conditions are below the limits of the type AND nature of the activity: temperature, visibility, rain, wind speed, etc.
- Optimum conditions: operation in calm conditions, possibly with light, steady winds.  
**Recommended wind strength: < 30 km/h**
- General visual inspection and condition assessment of the drone. General inspection: cables, connections, video connection, payload, etc. Payload condition, arms, base structure condition, and whether the bolts are properly tight.
- Condition of blades: clean, not broken, not cracked, no other damage. Visual inspection of the blades, paying special attention to possible mechanical damage and whether the propellers are properly fastened.
- Condition of motors: The coils are copper-colored, not black, no burnt smell, no great resistance when turning by hand, rotation is continuous, not chunky
- Condition of arms: properly secured, not broken or cracked, all fasteners (screws, rivets) in place
- Landing gear condition: not broken, not cracked, not warped, the drone is stable on the landing gear, the landing gear does not wobble on a flat surface. The landing gear and any accessories are securely fastened.
- Washing rod fitted and fixed in place.

- The washing system has been connected to the water source and, if necessary, to the mains electricity supply.
- The high pressure hose is connected to the drone.
- Hose entanglement during flight is a safety hazard. The hose should always be free of knots, and free to move in any direction. The high pressure hose is properly aligned, (6-8 m working with, free to move and free from knots).



- The remote control antennas are properly adjusted.
- The drone is placed on level ground, away from metal surfaces.
- Checking the batteries: no swelling, correct voltage, properly secured. All batteries charged and checked: radio station, drone, video equipment, and accessories.
- Drone battery status:  
(The state of the drone battery should be monitored before the flight using the charging indicator LEDs on the battery. We recommend starting the flight with a minimum of 80% battery charge).
- Unfold the drone's arms and tighten the fasteners.
- Unfold the propellers symmetrically.
- The remote controller is switched on and correctly set. The remote controller must ALWAYS be switched on before the drone battery is connected.
- Check the radio, telemetry, and video antennas.
- Check the remote controller's battery status, charge level.
- Check the live telemetry data on-screen, check button functions.
- NEVER leave batteries connected for prolonged periods.
- Before arming the drone, leave enough free space, stand at least 20 meters away from it.
- Perform compass calibration if necessary.
- Check the video signal on the display.
- Make sure the device has enough satellite connections.
- Check that the devices installed are working properly.
- Make sure that the task you have chosen is the one you want to carry out, is planned, and properly analyzed.
- Whether the take-off zone is sufficiently cleared.

## Post-arming tasks

- 6–8 meter wide work area designated.
- The remote control battery is sufficiently charged.
- The drone's battery is sufficiently charged.
- Camera image check, camera image available.
- Drone is position visible.
- Number of satellites is sufficient.
- Failsafe mode set
- The hose is vented.

## Pre departure tasks

- Checking the area before take-off, taking into account possible environmental hazards
- All switches in the correct position before take-off
- Automatic distance control is turned off  
( Right side 3-position switch, up position )
- Washing system is turned off
- External persons and persons involved in the operation are safe.
- Arm the drone and take off.

## After take-off and in-flight tasks

- Stabilize and hold the drone at a height of at least 2m.
- Test the left and right rotation functions, forward/reverse movements, right, left tilting.
- Check that the drone is stable and that there are no abnormal vibrations.
- Blades operate smoothly
- The drone is stable in the air (GPS)
- The drone works according to the instructions issued
- Flight data in order (Battery charge, Altitude, Speed, Heading, GPS connection)
- The drone is stable during flight near the surface to be cleaned.
- High pressure washer operation OK

## Preparing to operation

- Target Surface at a safe distance (7-10 m)
- High pressure system is turned on

## Activating the automatic distance control

- Approach surface to the Desired distance (target distance) +1m
- Enable the automatic distance control (D Button)
- Turn on the automatic distance control  
( Right side 3-position switch, middle or down position )

## During operation

- If the drone or remote controller battery is low, land the drone in a safe place.
- During the flight, the pilot must monitor the battery voltage, which should always be above 43.5 V, even when flying with the Maximum Take-off Mass (MTOM).
- When the battery voltage level drops under 43.5 V , start returning and landing the drone.

## After operation

- Turn off the automatic distance control ( Right side 3-position switch, up position )
- Target surface at a safe distance (7-10 m)
- Turn off the washing system
- Check the flight altitude and the maximum allowed distance.

## Start landing, tasks and inspections

- Ensure that the automatic distance control is turned off.
- If necessary, pre-adjust the hose.
- The people involved in the operation - and, external persons are safe

## After landing, tasks and inspections

- Switch off professional equipment if necessary.
- Switch off the drone by unplugging the battery from the connector.
- Switch off the remote controller.
- Clean the drone thoroughly (batteries, tools, camera, etc.).
- Disassemble, clean, check, and store all professional equipment properly.
- In the flight log, record the flight and any significant events. Accurate completion of this document is mandatory to monitor the operation and lifetime of the drone, and to facilitate properly scheduled servicing (every 300 flight hours).
- Record the nominal voltage remaining in the batteries used. After returning from the field, remove the batteries from the storage box and store them in a cool and well-ventilated place.
- DO NOT STORE batteries overcharged or fully discharged for extended periods of time

## Checklists

### Before first take-off

- General structural, mechanical inspection
- Inspection of propellers one by one, even if there is only minor damage, takeoff is prohibited.
- Tightness of the drone arms' fasteners
- Propellers in an unfolded state
- Visual inspection of the area performed
- Inspect the surface to be cleaned: If the wall surface is leaky, broken, or incomplete, radar signal stability may be reduced.
- Switch on the remote controller, and launch the ABZ Control app.
- When ABZ Control is waiting for the connection, turn on the drone by connecting the battery (the plug must be fully plugged in).
- If you are operating the drone in a country where the remote identification of drones is mandatory, verify in an appropriate application that the Dronetag is correctly broadcasting your drone operator ID before take-off ([see page 12](#)).

### Before every take-off

- Drone battery charge level. The state of the drone battery should be monitored before the flight using the charging indicator LEDs on the battery. We recommend starting the flight with a minimum of 80% battery charge.
- Remote controller battery charge level
- When ABZ Control is waiting for the connection, turn on the drone by connecting the battery (the plug must be fully plugged in).
- Check the connection between the remote controller and the drone.
- Verifying **Telemetry** live data (in case of failure, ABZ Control must be restarted).
- Whether the drone is in **Manual** (Loiter) mode (if not, press **button A** to switch).
- You are at a safe distance (at least 20 meters) from the drone.
- The high pressure hose is connected to the drone.
- The hoses are knot-free and properly aligned.
- The Automatic Distance Control System is Disabled/turned off.
- Switch to "Armed" mode by pushing the **left control stick** to the **down-right position**, until „Armed“ is shown on the display, then release the stick.
- After arming the drone, wait about 4 seconds for the motors to reach full speed before take-off.
- Take off to a safe height (at least 2m).

## After take-off

- Compass adjustment by a single 360° rotation around the vertical axis of the drone
- Check the stability and motion of the drone.
- Check the **battery status** and **voltage** frequently during flight.
  - If the drone or remote controller battery is low, land the drone in a safe place.
  - During the flight, the pilot must monitor the battery voltage, which should always be above 43.5 V even when flying with the Maximum Take-off Mass (MTOM). When the battery voltage level drops under 43.5 V, start returning and landing the drone.
- Land the drone carefully and at a safe descent speed.

## Before landing:

- The Automatic Distance Control System is Disabled/turned off.

## After landing

- Switch to „Disarmed” mode by pushing the **left control stick to the down position**, until „Disarmed” is shown on the display and the motors are completely stopped.
- At the end of the flight, first switch off the drone and then the remote controller.
- The drone can then be folded for transport. Make sure that the arms' fasteners are not in contact with the arm holder „C” clamps

## Emlid RTK (Optional)

The C10 drone can be equipped with Emlid LoRa system, which can be connected with Emlid RS+ or RS2+ for RTK positioning at centimeter precision.

Setting up the RS+ or RS2+ base is documented at Emlid's support pages:

<https://docs.emlid.com/reachrs2/>

<https://docs.emlid.com/reachrs/>

When the system is set up and working correctly, on the drone's controller the GPS Status shows the following based on the accuracy:

- GPS Lock – RTK float
- GPS Lock – RTK fixed

## Batteries and chargers

### Battery:

Only use batteries purchased directly from ABZ Innovation distributors! This ensures safe operations, full compatibility, appropriate data connection to the drone. Using 3rd party batteries void the drone's warranty.

General informations about the battery:

- 44,4 V nominal voltage
- 16000 mAh capacity
- 15C discharge value
- 12 Cells

### Charger:

Only use the original ABZ Smart Charger 3000! This ensures safe charge, full compatibility, appropriate data connection to the batteries. Using 3rd party chargers void the batteries' warranty.

- Power output: max. 60A/3000W
- Power Input: 16A/110-230V
- Capable of multiple charges at the same time
- Slow, Normal, Fast charge speed options
- Storage mode option

For continuous drone operation, use a set of four batteries. You can charge two batteries simultaneously while operating the drone with the remaining two (one active and one standby). On the field, charge two batteries simultaneously. To ensure long battery life, we highly recommend using balance charging. Also, let the batteries rest after charging before using them.

## Payloads

The C10 is only approved to be used with the payloads provided by the ABZ Innovation.

The operator is solely liable for using only properly secured, correctly connected payloads, accessories, which are approved and compatible for drone use.

It is the pilot's responsibility not to exceed the maximum combined accessories and batteries and payload weight, which is 13,15 kg , thereby not to exceed the MTOM with the fully equipped drone, which is 24,9 kg.

The payloads must not significantly affect the drone's center of mass, especially, when a heavy payload is mounted. It is highly recommended to install the payloads as close as possible to the drone's center.

## Troubleshooting

If any malfunction is experienced, contact an ABZ Innovation service center for further instructions. No repair attempts are allowed by the pilot or operator.

[abzinnovation.com/authorized\\_services/](http://abzinnovation.com/authorized_services/)

## Replacement parts

Only original replacement parts are qualified, directly from ABZ Innovation.

There are no life-limited parts of the drone, however propellers and motors must be inspected frequently, and in case of abnormalities, replacement is needed.

Other than replacing the propellers and the battery, every repair or replacement should be carried out only at an official ABZ Innovation distributor's service center by a trained and qualified technician.

Never repair any parts of the drone while it is powered on.

## List of spare parts and part numbers:

- Battery: ABZ-L10-GP-EC-001 (Normal size)
- Battery: ABZ-L10-GP-EC-002 (Compact size)
- Propeller CW: ABZ-L10-EFT-FR-006
- Propeller CCW: ABZ-L10-EFT-FR-007

## Replacing the propellers:

### Tools for replacement:

- HEX 4 key
- Threadlocking fluid (e.g. Loctite 243)
- Original ABZ Innovation C10 propellers

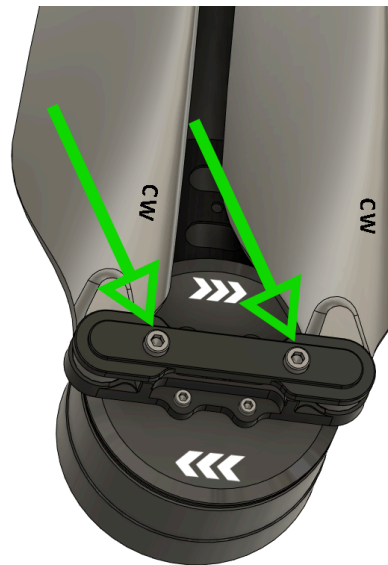

Carefully check the motor and propeller rotational direction. On the motors it is indicated with arrows, on the propellers „CW” or „CCW” are indicated.

Unscrew the two 4mm HEX screws, disassemble the fixing cap of the propellers, remove the propeller's upper washers, remove the propellers and install new propellers, reinstall the upper washer and fixing cap. Clean the 4mm HEX screws from threadlocking residues and apply new threadlocking material (according to the manufacturer's instruction). Tighten the screws until the propellers have zero axial and radial play, but still easy to fold and unfold them.

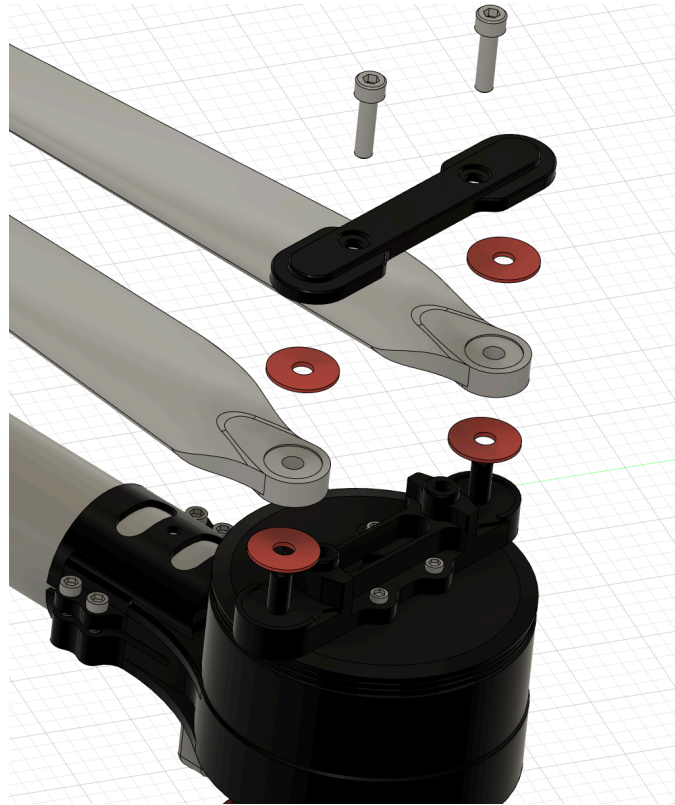

Obtain disposal information directly from local ABZ Innovation Distributors or Resellers. Always follow local regulations regarding disposal and recycling. If a part has ended life cycle or faulty/broken, it must be ensured not to be allowed to be used again, which can be carried out by an ABZ Innovation Distributor or Reseller.

## Compass calibration

Compass calibration can be performed under **Settings > IMU > Compass**.

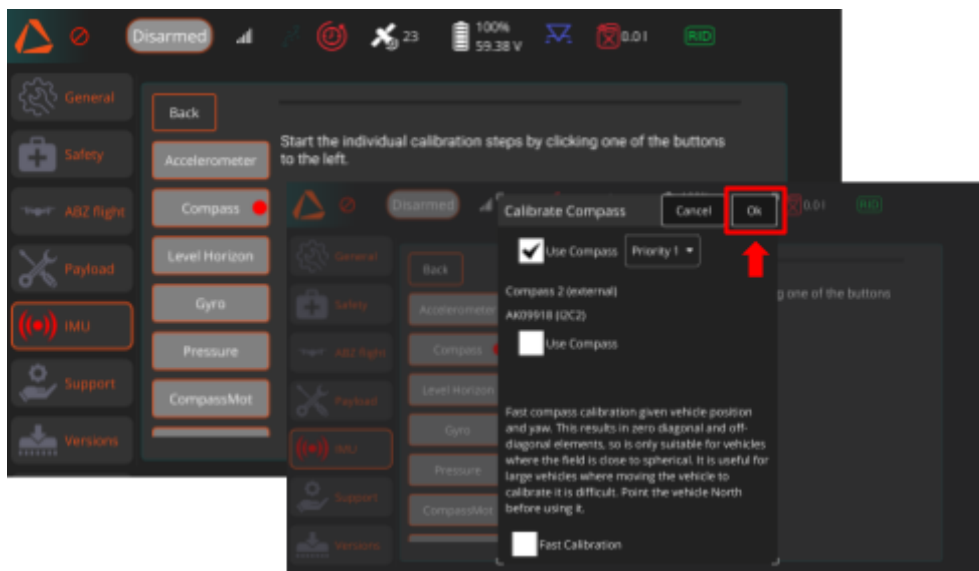

Make sure the settings match the photo below.

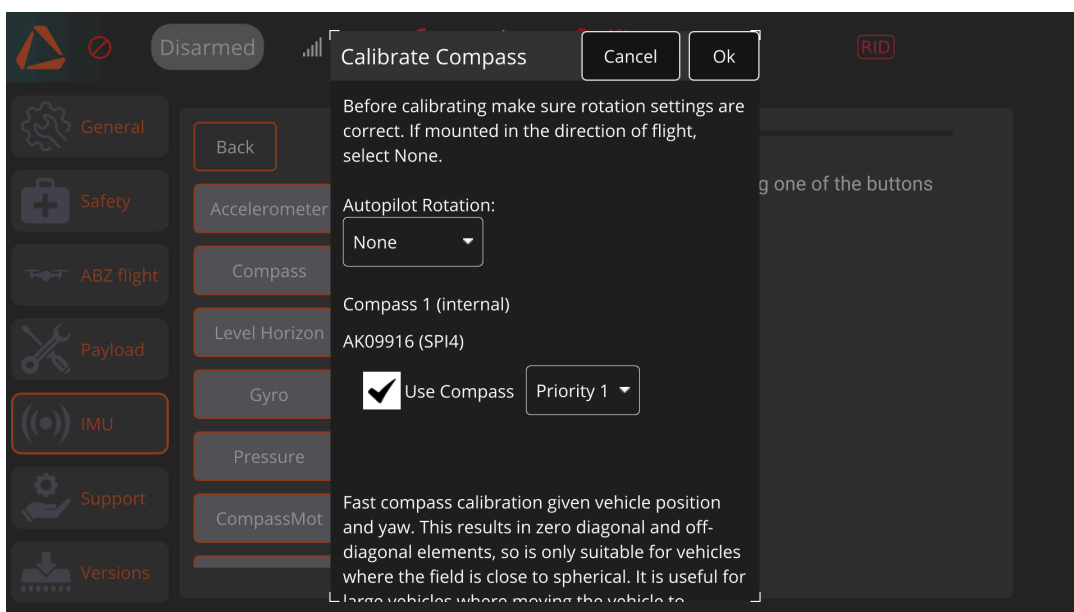

**The calibration should only be performed if requested by the software or instructed by the Support Center. Do NOT use Fast calibration!**

- The drone must be turned on, in „Disarmed” state.
- Remove any metal (e.g. keys, coins) and electronic objects from your pockets.
- The calibration sequence is initiated by pressing the "OK" button.
- Hold and Rotate the drone by hand 360° around all axes, and in both rotational directions
- Until the status bar is complete (usually a 1-2 minute operation).
- The result of the calibration is shown by the calibration quality feedback:

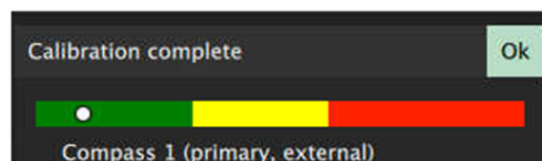

- Green: good quality calibration -> Only green means successful calibration!
- Yellow: medium quality calibration, consider recalibrating
- Red: not acceptable; please recalibrate

**After the calibration is complete, do NOT press the Restart button on the interface. Instead, click OK. Wait for the green progress bar to finish loading, then restart the drone by powering it off and on using the battery button (short press followed by a long press).**

<b>General Information</b> .....	<b>1</b>
Overview.....	1
Drone main parts.....	3
Specifications.....	4
<b>Safety requirements</b> .....	<b>5</b>
Child protection provisions.....	5
Operating conditions.....	5
Operation.....	6
Maintenance and storage.....	7
Drone handling and use precautions.....	7
Information about transport.....	9
In case of loss of signal and communication.....	9
Operational Safety.....	10
<b>Mandatory Remote identification with Dronetag</b> .....	<b>12</b>
Declaring an Emergency.....	15
<b>Remote Controller</b> .....	<b>16</b>
Internet connection.....	20
<b>ABZ Control Software Overview</b> .....	<b>21</b>
<b>Settings</b> .....	<b>26</b>
Safety – Setting up FailSafe.....	28
Abz Flight.....	29
RTK configuration.....	30
Software versions and Update.....	31
Payloads.....	31
Controlling the drone.....	32
Default control (mode 2).....	32
Altitude control.....	35
Cleaning System installation.....	36
Changing the nozzle holder.....	38
Adjusting the metal extension tube.....	38
Automatic Distance Control System (Radar-Based).....	39
The radar:.....	39
Important:.....	39
Key Automatic Distance Control System Functions:.....	40
Challenges Posed by Irregular Surfaces.....	42
Emergency Response & Error Handling.....	42
<b>Washing system operation</b> .....	<b>43</b>
Roles and Responsibilities.....	43
<b>Operational procedure</b> .....	<b>43</b>
1. Preparation.....	43
2. Hose Setup.....	44

3. Flight and Cleaning Operations.....	44
4. Concluding the Operation.....	45
<b>Flight.....</b>	<b>45</b>
<b>Flight Protocol and Checklists.....</b>	<b>46</b>
Before flight, tasks and inspections.....	46
Pre-arming tasks and inspections.....	46
Post-arming tasks.....	48
Pre departure tasks.....	48
After take-off and in-flight tasks.....	48
Preparing to operation.....	48
Activating the automatic distance control.....	49
During operation.....	49
After operation.....	49
Start landing, tasks and inspections.....	49
After landing, tasks and inspections.....	49
<b>Checklists.....</b>	<b>50</b>
Before first take-off.....	50
Before every take-off.....	50
After take-off.....	51
Before landing:.....	51
After landing.....	51
<b>Emlid RTK (Optional).....</b>	<b>52</b>
Batteries and chargers.....	53
Payloads.....	54
<b>Troubleshooting.....</b>	<b>55</b>
Replacing the propellers:.....	56
Compass calibration.....	58

If you have any questions, please contact us: [support@abzinnovation.com](mailto:support@abzinnovation.com)

ABZ Innovation Ltd. - [www.abzinnovation.com](http://www.abzinnovation.com)